



# Noise reducing pavements in Japan

- study tour report



Danish Road Institute  
Technical note 31  
2005

Road Directorate  
Guldalderen 12  
P.O. Box 235  
Denmark

Telephone +45 4630 7000

Telefax +45 4630 7105

[www.Roadinstitute.dk](http://www.Roadinstitute.dk)

Title Noise reducing pavements in Japan  
- study tour report

Dated December 2005

Authors Carsten Bredahl Nielsen, Hans Bendtsen, Bent Andesen, H.J. Ertman Larsen

Published by Road Directorate, Danish Road Institute

Copyright Road Directorate, All rights reserved

Photo Hans Bendtsen, Carsten Bredahl Nielsen

Print Electronic

ISSN electronic 1395-5530

ISBN electronic 87-91177-77-4

Reports published by the Danish Road Directorate  
can be requested from the bookshop:

Telephone +45 4322 7300

Telefax +45 4363 1969

e-mail [schultz@schultz.dk](mailto:schultz@schultz.dk)



# **Noise reducing pavements in Japan**

- study tour report

Carsten Bredahl Nielsen  
Hans Bendtsen  
Bent Andersen  
H.J. Ertman Larsen

Danish Road Institute  
Technical note 31  
2005



# Contents

<b>Acknowledgement</b> .....	<b>7</b>
Readers guide.....	8
<b>1. Summary</b> .....	<b>9</b>
1.1 Goal of Scanning Tour.....	9
1.2 Main Findings.....	9
Proven technology.....	9
New technology, ready for implementation.....	9
New technology, ready for test sections.....	9
1.3 Japan.....	9
Geographic issues.....	9
Political issues.....	10
Road Infrastructure in Japan.....	11
1.4 Important knowledge obtained in Japan.....	11
Structural durability.....	12
Acoustic durability.....	12
The double layer paver.....	13
Performance based contracts.....	13
<b>2. Preface</b> .....	<b>15</b>
<b>3. Introduction</b> .....	<b>16</b>
Aim.....	16
Topics.....	16
Preparation.....	16
Program.....	16
Dutch and Danish introductions.....	17
<b>4. Public Works Research Institute (PWRI)</b> .....	<b>19</b>
4.1 Highlights.....	19
4.2 Introduction to PWRI.....	19
4.3 Presentations at PWRI.....	21
Practical use of noise reducing pavements in warm area.....	21
Low-noise pavements in Tokyo.....	21
More durable porous asphalt pavements.....	22
Trend of Air Void Assessment Technology.....	23
Method for evaluating tire/road noise level.....	24
Function recovery and maintenance of porous pavements in Japan.....	25
Porous elastic pavements.....	27
Structural durability of porous pavements in Japan.....	27
4.4 Demonstrations at PRWI.....	28
Cleaning procedures for porous pavements in Japan.....	28
Elastic porous pavements.....	29
Active noise control.....	30
<b>5. TOA DORO Road Construction Company</b> .....	<b>32</b>
5.1 Highlights.....	32
5.2 Introduction to TOA DORO.....	32



5.3	Development of porous asphalt in Japan.....	32
5.4	Durability of porous pavements .....	32
5.5	Asphalt pavers .....	33
5.6	High performance binders .....	33
<b>6.</b>	<b>NIPPO Road Construction Company .....</b>	<b>37</b>
6.1	Highlights .....	37
6.2	Introduction to NIPPO.....	37
6.3	Doble layer paving machine.....	37
6.4	Noise reducing pavements.....	38
6.5	High performance surface treatmens.....	38
6.6	New cleaning machines.....	40
6.7	Site inspection in Yokohama.....	40
<b>7.</b>	<b>Civil Engineering Research Institute of Hokkaido (CERI).....</b>	<b>45</b>
7.1	Highlights .....	45
7.2	Introduction to CERI.....	45
7.3	Presentations at CERI.....	46
	East Nippon Expressway Co. Ltd. ....	46
	Improving the performance of porous pavements.....	49
	Effectiveness of porous pavements against skidding on winter roads .....	49
	Using materials recycled from porous pavements .....	50
	Winter maintenance .....	50
7.4	Site inspection East Nippon Expressway Company.....	50
	Highway north of Mikasa.....	50
	Porous pavements for urban roads .....	52
<b>8.</b>	<b>Greater Tokyo area.....</b>	<b>53</b>
<b>9.</b>	<b>Conclusions .....</b>	<b>55</b>
<b>10.</b>	<b>References .....</b>	<b>57</b>
<b>11.</b>	<b>Contacts in Japan .....</b>	<b>58</b>
11.1	Names and affiliation .....	58
11.2	Contact addresses .....	59
11.3	The Dutch-Danish delegation.....	60
<b>12.</b>	<b>Program for the scanning tour .....</b>	<b>63</b>





# Acknowledgement

We, the Directors of the Road and Hydraulic Engineering Institute in the Netherlands and the Danish Road Institute will like to convey our deepest acknowledgement to colleagues in Japan for the support of the Joint Dutch-Danish Scanning Tour to Japan.

Your staff was instrumental to a very successful tour and was greatly appreciated by the delegates of the scanning tour. The presentations were extremely informative and provided a basis for the advancement of the joint Dutch-Danish Noise Abatement Program.

We would be happy to have the opportunity to reciprocate your efforts, as well as your hospitality, should you visit our countries in the future.

*Pieter Stienstra*

Director of Road and Hydraulic Engineering Institute in the Netherlands

*Gert Ahé*

Director of the Danish Road Institute/Road Directorate

## Readers guide

This report presents knowledge collected 14<sup>th</sup>-18<sup>th</sup> November 2005 by staff from The Danish Road Institute (DRI) and the Road and Hydraulic Engineering Institute (DWW) in the Netherlands on a scanning tour to Japan in order to obtain the latest experiences with the use and maintenance of porous pavements in Japan as well as new concepts, and ideas in the field of noise abatement. The **summary** contains the key findings from the scanning tour.

The detailed knowledge is presented in subsequent chapters; one from each of the institutions visited. These were:

- PWRI: Public Works Research Institute, Tsukuba
- TOA DORO: Toa Doro Road Construction Company, Tsukuba
- NIPPO: Nippo Road construction company, Tokyo
- CERI: Civil Engineering Research Institute of Hokkaido, Sapporo

First the highlights of the visit and an introduction of the institution are presented followed by a summary of presentations and site inspections. Topics covered are:

- Improvements in the structural durability
  - PWRI: High viscosity modified binders
  - TOA DORO: Special high viscosity modified binders
  - CERI: High durability, high viscosity modified binders for cold regions
  - TOA DORO: Binder property tests and ravelling test at low temperatures
  - CERI: Construction and maintenance of porous pavements in cold, snowy climate
  - NIPPO: Advanced surface treatments
  - NIPPO: Porous pavements on high traffic urban roads in Yokohama
  - CERI: Site inspections at East Nippon Expressway Company
  - CERI: Development of a hybrid pavements
- Improvements in the acoustic durability
  - PRWI: New cleaning machines and strategies
  - NIPPO: Water jet cleaning (Tornado)
  - PRWI: Porous elastic pavements
  - NIPPO: Porous pavements on high traffic urban roads in Yokohama
  - CERI: Site inspections at East Nippon Expressway Company
- The paving of two layer porous pavements in one application
  - TOA DORO: Multi-Asphalt Paver (MAP)
  - NIPPO: Double Layer Paver
- Performance based contracts including tire/pavement noise
  - PRWI

The report ends with **conclusions** and gives detailed information on **contacts** in Japan and the Dutch-Danish delegation.

# 1. Summary

## 1.1 Goal of Scanning Tour

A Dutch/ Danish scanning tour visited Japan 14<sup>th</sup>-18<sup>th</sup> November 2005. The goal of the study tour was to analyse the recent Japanese developments in the field of Durable Silent Roads. It is aimed that this analysis will help the Dutch Noise Innovation Program in implementing silent roads.

## 1.2 Main Findings

The main findings of the tour that are of interest for possible use on the Dutch main road network are.

### Proven technology

- Binders are used to obtain improved lifetime. Highly modified SBS binders play a key role in this development.
- Two layer pavers that can lay two layer porous pavements in one application are used to improve the durability and reduce construction time, costs, and traffic congestion during construction.
- New contracts are used. These include acoustic requirements and tendering on most economic bid.

### New technology, ready for implementation

- Special surface treatments using new aggregate materials and resin binders are developed to improve lifetime at heavily loaded locations like intersections in urban areas.
- Cleaning strategies using improved equipment are developed. This enables operation at higher speed (10-20 km/h), resulting in less traffic congestion during cleaning.

### New technology, ready for test sections

- Porous elastic pavements are developed to obtain superior noise reduction (claim > 10 dB (A)).

## 1.3 Japan

In the evaluation of the Japanese innovations it is very important to understand why the solutions are chosen, i.e. what the driving force for innovation is. Therefore it is important to understand the typical Japanese geographic circumstances (incl. climate), the political issues and the Japanese infrastructure. Below they are briefly discussed.

### Geographic issues

The population in Japan is about 128 million people. The number of Japanese aged 65 or above has reached 24.3 million, accounting for 19 percent of the population. The figure is the highest among industrialized nations according to the Public Management, Home Affairs, Posts and Telecommunications Ministry. A larger part of Japan is mountainous making it unsuitable to live in. Therefore, the population can only live

in a limited area, which leads to high population densities, certainly in the bigger agglomerations of Tokyo, Yokohama, Kobe, Osaka etc.

The western part of Japan has a cold climate with severe winters with a lot of snow. The eastern part of Japan is much warmer with in the southern part a sub tropic climate. In Japan typhoons and earthquakes can destroy large areas. In constructing buildings and infrastructure this must be taken into account.

### **Political issues**

An aging society is a serious problem Japan is confronted with. Prime Minister Junichiro Koizumi is advocating cutting governmental share in pension to make it sustainable. This also put restrictions on the budget for road maintenance in general and noise abatement specifically.

The Environmental Quality Standards for Noise Pollution is at daytime 70dB and at night time 65dB. In 2003 the Ministry of Land, Infrastructure and Transport concludes that the level of noise pollution from arterial roads has not achieved the environmental quality standards nation-wide and is in a severe situation. The major noise problems are observed on urban roads with a maximum speed of 40 - 60 km/h.

Besides the noise reducing performance porous pavements are also used to improve traffic safety and comfort. Overall, there is a series of reasons for using porous pavements in Japan:

1. To improve the traffic safety by improving skid resistance.
2. To improve the traffic safety and comfort for drivers and pedestrians in rainy periods by leading the water from the pavement surface thereby reducing splash and spray.
3. To reduce the risk of flooding in periods with heavy rainfall by leading water from the pavement surface to the gullies and to the subbase.
4. To improve the microclimate in cities during night time by retaining rain giving a slower evaporation of water from the road surface and by this reducing the temperature.
5. To reduce traffic noise.

## Road Infrastructure in Japan

Japan's large metropolitan areas around Tokyo, Osaka and Nagoya are served by highly efficient public transportation systems. Consequently, many residents do not own a car or even a driving license. Outside the big cities, however, public transportation tends to be inconvenient, and most people rely on a car.

In Japan, cars drive on the left side of the road and have the driver's seat and steering wheel on the right. The legal minimum age for driving is 18 years. Road signs and rules follow international standards, and most signs on major roads are in Japanese and English. Drinking and driving is strictly prohibited.

The typical speed limits are 100 km/h on expressways, 40 km/h in urban areas, 30 km/h in side streets and 50 km/h elsewhere, however, it is quite usual for drivers to exceed the speed limits by about 10 km/h. Most roads in Japan are toll free with the exception of expressways and some scenic driving routes. Road conditions tend to be good, although side streets in the cities can be rather narrow. Traffic congestions are a frequent problem in and around urban centres.

*By japan-guide.com*

The length of the total road network in Japan is around 1.2 million km. The length of the national roads administrated by the Ministry of Land, Infrastructure and Transport is 21,900 km. Japan has a total motorway network of 6,900 km mainly paved with bituminous pavements; only 500 km has cement concrete pavement. Porous pavements was standardised in 1995 and are widely used in Japan both on highways and in urban areas. Today the total area of porous pavements is 50 million m<sup>2</sup> and it is still increasing. Noise reducing pavements are used on 20 % of the national roads. On toll roads more than 50 % of the pavement is porous. Porous asphalt is mainly used in dense inhabited and urban areas but also to some extent in flat non-urban areas.

### 1.4 Important knowledge obtained in Japan

The aim of the scanning tour was to obtain the latest Japanese experiences with the use and maintenance of porous pavements as well as new concepts and ideas in the field of noise abatement. The focus was on the following topics related to porous pavements:

- Improvements in the structural durability
- Improvements in the acoustic durability
- The paving of two layer porous pavements in one application
- Performance based contracts including tire/pavement noise

The current situation in Japan on these topics is summarized below including the perspective for the use in Japan and the possible implementation in Europe.

### **Structural durability**

The structural durability of porous pavements in Japan is generally the same as the durability of dense graded asphalt mixes. In the warm regions the structural durability of porous pavements is 10 years or more, and in the cold regions 7-10 years. The first tests with porous pavements in the Tokyo area were performed in 1987. The performance of porous pavements at the time was very poor (only one year durability). This has led to the development and widespread use of high viscosity modified binders.

Structural damage of porous asphalt is a serious problem in cold regions. Snow removal operations by snowploughs causes severe damage in the porous asphalt and rutting and ravelling occurs after a few years. This has led to use of special high viscous SBS modified binders for cold regions and to the development of a 'hybrid' pavement with a dense structure and an open surface texture.

Porous pavements are used in urban areas even at intersections and bus stops. At some intersections a special epoxy based surface treatment is applied by hand in order to improve durability.

The use of high viscosity modified binders is wide spread in Japan and considered a standard and cost-effective measure to obtain more durable porous pavements. The prospective is further developments and use of special binders for cold regions. There is no evidence not introducing these binders in Europe based on specific cost-benefit analysis. Also, special surface treatments could be introduced in restricted areas.

Interesting findings:

- Japanese technology using high viscous SBS modified binders and other special binders to improve structural durability of porous pavements and reduce ravelling.
- Use of special surface treatments in intersections in urban areas in order to improve shear resistance, reduce ravelling, and improve skid resistance.

### **Acoustic durability**

Noise has been measured on porous pavements. As a reference a 13 mm maximum aggregate size dense asphalt concrete are usually used. For single and two layer porous pavements noise reduction was 2-5 dB for trucks and 4-7 dB for passenger cars. The highest reductions are obtained on two layer porous pavements. Results from long-term measurements have shown that traffic noise from porous pavements increases by around 4 dB over a 5 years period. The increase is attributed to the general wear and clogging of the pavement. Research in Japan indicates that clogging of porous pavements on urban roads occurs after 3-4 years. Cleaning of porous pavements has been performed in Japan since the introduction of porous pavements in 1995 but it has been observed that the effect of cleaning is not durable. Different low speed cleaning machines (1-2 km/h) using high pressure water spraying has been developed since 1995 but now more cost effective cleaning strategies have been developed with cleaning at higher speed (10-20 km/h) and more frequent cleaning (up to once a week).

The first generation machines are referred to as function recovery machines as they aim at recovering the function of a clogged porous pavement. The new cleaning ma-

chines are referred to as function maintenance machines as they aim at maintaining the function of the pavement at all times. Cost-benefit analysis [4] demonstrates that the new cleaning strategies are more cost effective and better maintain the acoustic properties of the pavement. The new cleaning machines are in operation in Japan and new generations are under development. From cost-benefit considerations it seems obvious to introduce the Japanese cleaning strategies in Europe as cleaning operations at higher speed will reduce disruption to road users significantly and maintain the acoustic properties of the porous pavement for a longer time.

Porous elastic pavements are under development and full scale testing in Japan. These pavements are very effective noise reducing pavements, but the price is high and an acceptable lifetime has still to be proven. The noise reduction for passenger cars was 7-11 dB and 5-8 dB for trucks compared to a dense asphalt concrete. It is believed that further developments could lead to a lifetime of 5-10 years. The pavement is very innovative but still under development and therefore it is recommended to observe the prospective in Japan.

Interesting findings:

- New Japanese cleaning strategies with better cleaning machines, cleaning at higher speed (10-20 km/h), and more frequent cleaning (once a week).
- Developments in very silent porous elastic pavements (~10dB(A)).

### **The double layer paver**

Tests with two layer porous pavements in Japan started in 1998 and are mainly used on urban roads. The paving of two layer porous pavements in one application as a warm in warm process is widely used in Japan. A compact machine is produced by the WIRTGEN Company in Japan and a similar but larger machine is manufactured by the BAM Company in Europe. The integration of the top and the bottom layer in one laying process improves the durability of the pavement and construction time, costs and disruption to road users are reduced significantly.

Apparently they have no technical or logistical problems in Japan with the paving of two layers in one operation and since the technique has already been developed and introduced in Europe it seems obvious to implement the Japanese knowledge in Europe.

Interesting findings:

- Use of double layer pavers that can lay two layer porous pavements in one application as a 'warm in warm' process. The integration of the top and the bottom layer in one laying process improves the durability of the pavement and reduces construction time and costs, and by this also the interruption of the traffic flow.

### **Performance based contracts**

In Japan performance based specification contracts have been tested since 1998 and comprehensive evaluation contracts since 1999. Both contract types include tire/pavement noise as a performance indicator but the comprehensive contracts include other factors than the price such as work plan, construction technique and safety.

The total number of contracts in 2003 was 131. The tire/pavement noise is measured by a special Japanese vehicle named "Road Acoustic Checker" which is standardized in Japan. The vehicle has a measurement tyre with a special tread pattern claimed to enhance the difference between ordinary dense graded pavements and low noise pavements. Shortly after laying the measured noise level must not exceed 89 dB at 50 km/h. One year after the noise level must not exceed 90 dB.

Out of 190 performance based contracts, 189 were satisfactory and it is concluded that the contracts encouraging the use of advanced technologies in Japan. In Europe similar experiences with performance based contracts are being developed. If tire/pavement noise is included in the contract as a performance indicator it is crucial to have a sensitive standardized noise measurement method which is the case in Japan. The problem with such contracts only appears if the tire/pavement noise level is not satisfactory which has not been the case in Japan. Before implementing noise as a performance indicator into contracts in Europe a suitable measurement method should be implemented and accepted for a period of time. In Japan, one of the problems not being addressed so far in these contracts is how to ensure the acoustic durability of the pavements since there are only measurements after one year.

Interesting findings:

- Use of functional contracts in which noise reduction requirements are incorporated.
- Use of evaluation on most economic bid.



## 2. Preface

The 14<sup>th</sup>-18<sup>th</sup> November 2005 staff from The Danish Road Institute (DRI) and the Road and Hydraulic Engineering Institute (DWW) in the Netherlands carried out a scanning tour to Japan in order to obtain the latest experiences with the use and maintenance of porous pavements in Japan as well as new concepts, and ideas in the field of noise abatement. The members of the joint delegation were:

- Leader of the delegation, Dr. Rob Hofman (DWW)
- Deputy Director of research Hans Ertman Larsen (DRI)
- Senior researcher Bent Andersen (DRI)
- Senior researcher Hans Bendtsen (DRI)
- Senior researcher Carsten Bredahl Nielsen (DRI)

The scanning tour was part of the research work carried out in the “DRI-DWW noise abatement program” [1] which is a joint research program carried out by the Dutch (DWW) and the Danish (DRI) road research institutes in the period from 2004 to 2007. The program is a part of the Dutch Innovation Program on Noise [2] also called the IPG research program.

The main objectives of the scanning tour were to collect information on:

- Clogging of porous pavements
- Ravelling of porous pavements
- Modified bitumen used for porous pavements.

These research themes are part of the DRI-DWW noise abatement program.

The scanning tour has been organised by DRI and the Public Works Research Institute in Japan (PWRI). An intensive program including meetings with Japanese experts as well as visits to test sites and laboratories was planned by PWRI.

The information obtained is an important input to the research and development work in Denmark and the Netherlands improving the acoustical and structural durability of noise reducing pavements. The delegates of the scanning tour believe that the meetings have been a strong factor in developing the scientific cooperation between Japan, Denmark and the Netherlands in the field of traffic noise abatement using noise-reducing pavements.

This report presents highlights obtained from the scanning tour.

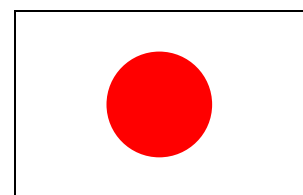
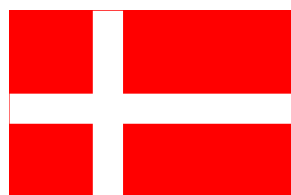

# 3. Introduction

## Aim

The aim of the scanning tour was to obtain the latest Japanese experiences with the use and maintenance of porous pavements as well as new concepts and ideas in the field of noise abatement.

## Topics

Previous to the scanning tour the following list of main topics of interest and research questions was developed:

- Optimisation of the noise reduction of single layer and two-layer porous pavements
- Improving the acoustical durability of porous pavements
- Improving the structural durability of porous pavements
- Porous elastic pavements
- Clogging of porous pavements
- Cleaning of porous pavements
- Winter maintenance of porous pavements
- Splash and spray from noise reducing pavements
- Porous pavements and traffic safety
- Noise reducing thin pavements
- Practical use of noise reducing pavements on the road network with a special focus on highways.

## Preparation

As a part of the scanning tour the latest reports from other European study tours to Japan have been investigated, among these reports by Ulf Sandberg [3, 4] from VTI in Sweden and by Jan Voskuilen [5] from DWW in the Netherlands.

## Program

The framework of the 5 days program was the following:

Day	Program	Location
Monday 14 <sup>th</sup> November	Public Works Research Institute Visit to test tracks	Tsukuba
Tuesday 15 <sup>th</sup> November	Public Works Research Institute TOA DORO road construction company Laboratory visit	Tsukuba
Wednesday 16 <sup>th</sup> November	Public Works Research Institute Nippo Road construction company Site inspection	Tsukuba Tokyo Yokohama
Thursday 17 <sup>th</sup> November	Civil Engineering Research Institute of Hokkaido East Nippon Expressway Company Site inspection	Sapporo Mikasa
Friday 18 <sup>th</sup> November	Nihon University Site inspection	Tokyo



Figure 1. Staff from PWRI and the Dutch Danish Delegation in front of the PWRI headquarters in Tsukuba near Tokyo.

### **Dutch and Danish introductions**

An important issue of the Dutch-Danish scanning tour was to facilitate a two-way exchange of research results and experiences with Japanese colleagues. Therefore during the meetings in Japan the members of the Dutch-Danish delegation gave a series of presentations on our new research results as well as on practical experiences in the two European countries:

- Introduction to the IPG road noise road research program in the Netherlands, Rob Hofman (DWW), e-mail: [R.Hofman@DWW.RWS.MinVenW.NL](mailto:R.Hofman@DWW.RWS.MinVenW.NL)
- The DRI-DWW noise abatement program, Hans Jørgen Ertman Larsen (DRI), e-mail: [hje@vd.dk](mailto:hje@vd.dk)
- Practical use of porous pavements in the Netherlands, Rob Hofman (DWW)
- Pavement management systems in Denmark, Hans Jørgen Ertman Larsen (DRI)
- Knowledge on clogging of porous pavements in Denmark, Carsten Bredahl Nielsen (DRI).
- Improving the structural lifetime of porous pavements in Denmark, Carsten Bredahl Nielsen (DRI).
- Test of two layer porous pavements in Denmark, Hans Bendtsen (DRI)
- Test of noise reducing thin layers in Denmark, Bent Andersen (DRI)
- Winter maintenance of porous pavements in the Netherlands, Rob Hofman (DWW).

The contents of these presentations are not reported in this report. However, information can be obtained from the presenters and the web pages of DRI ([www.roadinstitute.dk](http://www.roadinstitute.dk)) and DWW ([www.rws.nl/rws/dww/home/engels/index\\_eng.html](http://www.rws.nl/rws/dww/home/engels/index_eng.html))

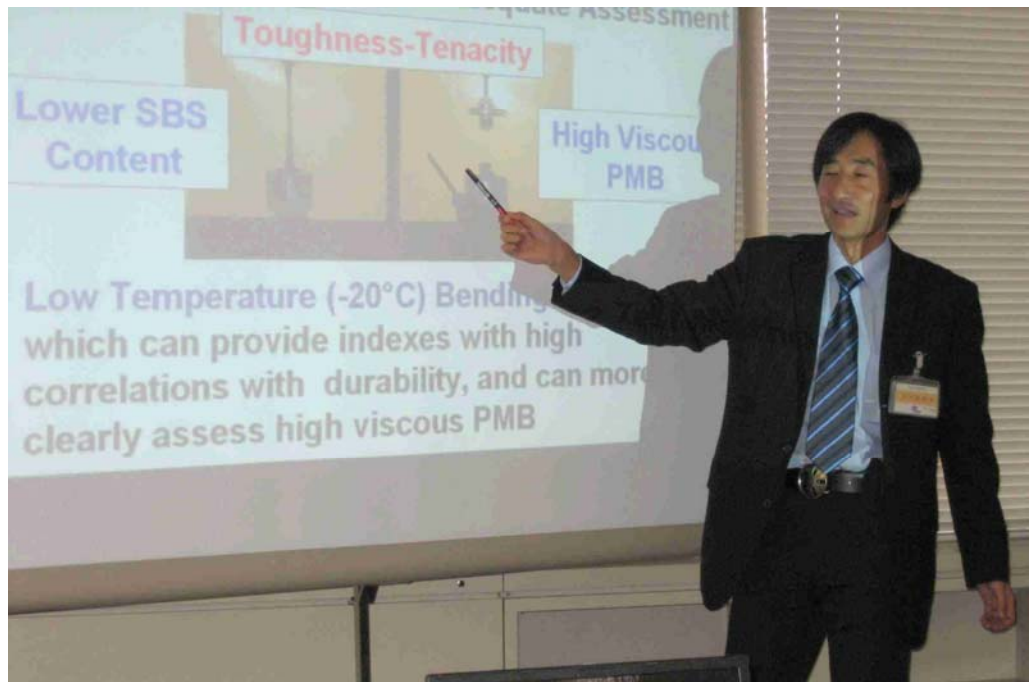

Figure 2. Technical presentation at the two days meetings at PWRI.

## 4. Public Works Research Institute (PWRI)

### 4.1 Highlights

- The use of high viscosity modified binders is wide spread in Japan and considered a standard and cost-effective measure to obtain more durable porous pavements.
- The structural durability of porous pavements in Japan is generally the same as the durability of dense graded asphalt mixes.
- Porous elastic pavements are under development and full scale testing in Japan. These pavements are very effective noise reducing pavements, but the price is high and an acceptable lifetime has still to be proven.
- In Japan performance based specification contracts are used with the tire/pavement noise as a performance indicator.
- Function recovery machines aim at recovering the function of a clogged porous pavement. The new cleaning machines are referred to as function maintenance machines as they aim at maintaining the function of the pavement at all times.
- Cleaning of porous pavements with high pressure air (no water) and new cleaning strategies (once a week) is cost effective.

### 4.2 Introduction to PWRI

*Team leader Mr. Kazuyuki KUBO, Road technology research group, PWRI*

Public Works Research Institute (PWRI) is an 80 years old research institution. In 2001 parts of PWRI were privatised and the rest kept public as the Land and Infrastructure Research Institute. PWRI has around 200 employees carrying out research and development in civil engineering technologies and road infrastructure, having many large-scale testing facilities including large test tracks for e.g. accelerated testing of pavements. PWRI has close connections with national and international organizations, which construct and manage infrastructure, often cooperating with academic organizations and private companies.

PWRI has several facilities to test road pavements – among others a full-scale test tunnel for fog and rain tests and a circle loop test track with four automatic controlled heavy three-axle trucks with an axle load of 16 tonne. The position of the trucks is controlled from a pc with a GPS at an accuracy of  $\pm 30$  to 50 mm. The operation speed is 0 – 40 km/h.



Figure 3. The test track facility at PWRI.



Figure 4. The PWRI test tunnel. Testing of warning systems for wind and severe meteorological conditions and research into visibility of road markings.



Figure 5. The circle test track at PWRI and an automatic controlled three axels heavy truck without driver.

### 4.3 Presentations at PWRI

#### **Practical use of noise reducing pavements in warm area**

*Senior researcher Mr. Yasufumi SAKAMOTO, Road technology research group, PWRI*

The length of the total road network in Japan is around 1.2 million km. The length of the national roads administrated by the Ministry of Land, Infrastructure and Transport is 21,900 km. Japan has a total motorway network of 6,900 km mainly paved with bituminous pavements; only 500 km has cement concrete pavement. The typical speed limits are 100 km/h on expressways, 40 km/h in urban areas, 30 km/h in side streets and 50 km/h elsewhere, however, it is quite usual for drivers to exceed the speed limits by about 10 km/h. Noise reducing pavements are used on 20 % of the national roads. Porous asphalt has a built-in air void in the range 17 to 23 %. The maximum aggregate size is between 5 and 13 mm and the binder is high-viscosity modified bitumen. Besides the noise reducing performance porous pavements are also used to reduce the amount of surface water during rain in order to improve traffic safety and comfort. Porous asphalt is mainly used in dense inhabited and urban areas but also to some extent in flat non-urban areas. The noise reduction last for 2-3 years on urban roads (40-60 km/h) but on high speed expressways the acoustic durability is 10 years and the structural durability more than 10 years.

#### **Low-noise pavements in Tokyo**

*Researcher Mr. Junichi MINEGISHI, Tokyo Metropolitan Government, Institute of civil engineering*

The first tests with porous pavements in the Tokyo area were performed in 1987. Since the performance of porous pavements with straight and rubberized bitumen was

very poor (only one year of durability) the binder was replaced by a polymer modified binder, and later to a high viscosity modified binder. The acoustic durability was then found to be about six years. Low noise pavements were standardised in 1995 and have been used on a larger scale since then. Tests with two layer porous pavements started in 1998 and an initial noise reduction of 6-8 dB was achieved. The single layer porous pavements in Tokyo have a thickness of 5 cm and a maximum aggregate size of 13 mm. The built-in air void is 20 %. So far, 400 km of porous pavements have been constructed in Tokyo. An average noise reduction of 4.6 dB has been measured on new single layer porous pavements compared to the existing pavement (using a special Japanese CPX method). Two-layer porous pavements are constructed with a 20 mm thick 5-8 mm aggregate top-layer, and a 50 mm thick 13 mm aggregate lower layer. The initial noise reduction obtained was 6.1 dB.

In Tokyo the tire/pavement noise is measured with a van equipped with a special tire mounted on a car behind the rear axle, and one microphone near the side of the tire (CPX measurement type). Measured with this system dense asphalt pavements (with 20 mm max. aggregate size) have a noise level of 100 dB, and porous asphalt pavements 87 to 89 dB immediately after construction. The tire has a special tread pattern developed to accentuate differences between dense and porous pavements (near 1 kHz). The same type of test vehicle is used throughout Japan. Five such vehicles exist in Japan.

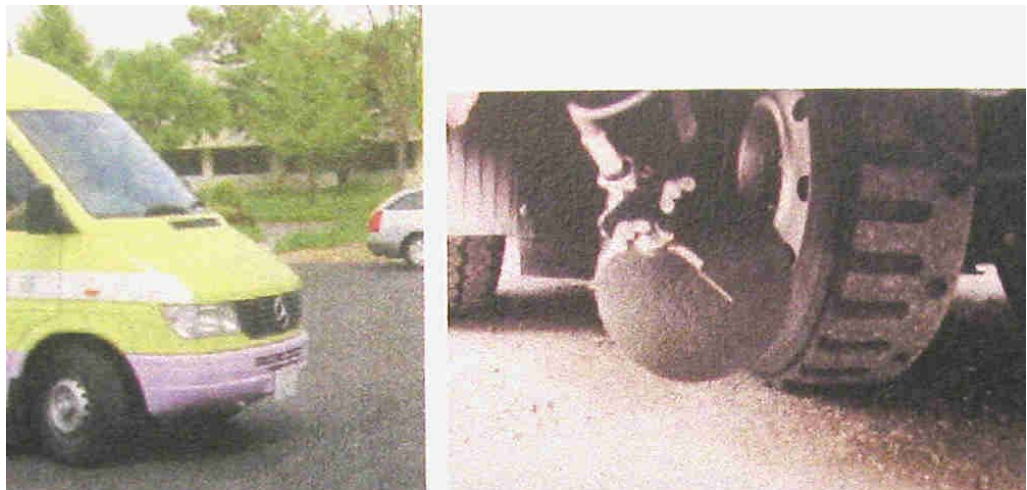

Figure 6. The Japanese Road Acoustic Checker (RAC) with a special tire mounted on a van behind the rear axle, and one microphone near the side of the tire (photo of slide from the presentation).

### **More durable porous asphalt pavements**

*Director Mr. Keizo KAMIYA, Central Nippon Expressway Company Ltd., Road research department*

Central Nippon Expressway Company is a private toll road company that operates in the Tokyo and Osaka regions and has the responsibility to provide safe and comfortable roads. The total length of toll roads in Japan is 6,900 km. The main purpose to use porous pavements is to improve road safety during rain. It has been considered to develop methods quantifying splash and spray, but no such methods are available in Japan at the moment. Today the total area of porous pavements is about 50 million m<sup>2</sup>



and it is still increasing. On toll roads more than 50 % of the pavement is porous. Japan is divided in the snowbound cold areas in the north and the general (warm) regions in the south. The pavement guidelines are different in these two regions. In the cold regions a built-in air void of 17 % is used and in the general regions 20 %. In both regions high-viscosity polymer modified bitumen with an SBS content of 8 % or more is used. In the general regions the structural durability of porous pavements is 10 years or more, and in the cold regions 7-10 years. With this special binder the resistance against ravelling and stripping is in general very high. Special tests methods to assess the high viscous polymer modified bitumen have been developed. To reduce the costs of porous pavements it has been considered to reduce the amount of modifier in the general regions.

Permeability of the pavements is measured as the flow-out time of 400 ml water. Permeability did not decrease significantly over a 5 years period, both for 5-10 mm aggregate and 5-13 mm aggregate pavements. Noise reduction was measured by the abovementioned special car with a microphone mounted behind a special rear tire (CPX measurement type). The increase in measured noise level was about 2 dB over 5 years.

### **Trend of Air Void Assessment Technology**

*Mr. Osamu FUNAHASHI, Central Nippon Expressway Company Ltd.,  
Environmental and landscape division*

Research on the structure of porous pavements and the built-in air void have been carried out. The condition of the voids can be measured by noise measurements and by analyses of drilled cores. But these measurements are both time and resource consuming. Therefore ultrasonic and electromagnetic wave measurements systems have been developed and the instruments mounted in a van. The clogging of porous pavements is assessed from the absorption of ultrasonic sound or reflection of electromagnetic waves. Clogging reduces the absorption of sound in the frequency range 3 – 8 kHz and increases the reflection of the electromagnetic waves. Both measurements can be performed at a speed of 80 km/h.

‘Ultra’sonic waves of 5-8 kHz are used to monitor the upper layer, and 2.5 to 4.0 kHz to monitor the porosity of the lower layer. The percentage of observed absorption is used to determine the level of clogging as follows:

	<b>Clogged</b>	<b>Slightly clogged</b>	<b>Good condition /No clogging</b>
Upper layer	Under 30 %	30-41 %	Over 41 %
Lower layer	Under 30 %	30-35 %	Over 35 %

As the frequency of the ultra sonic waves are indicated to be in the range from 2.5 to 8 kHz this system actually uses high frequency sound and measures the sound absorption at high speed of the pavement surface. In general it is found that the ultrasonic and electromagnetic measurements are consistent with observations on drilled cores. These methods are still under development.

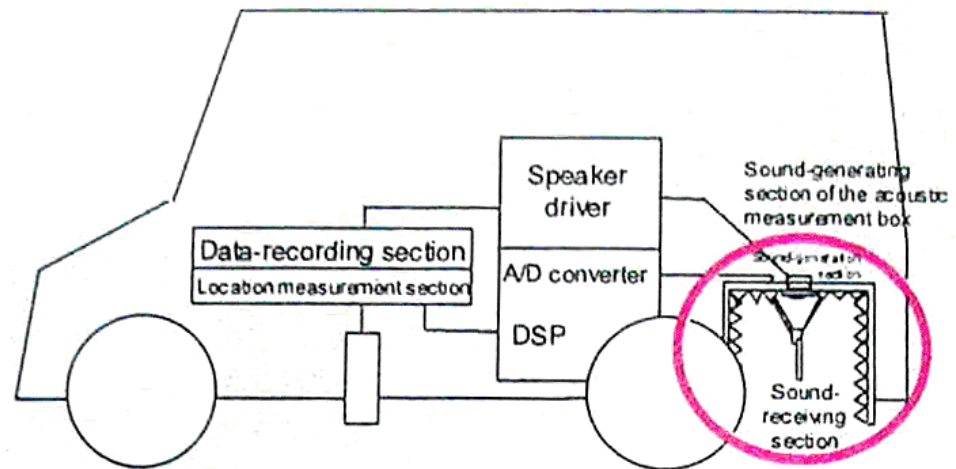

Figure 7. The principle of the ultra sonic measurement system (photo of slide from the presentation).

### Method for evaluating tire/road noise level

Mr. Masaru TERADA, Pavement research team, PWRI

In Japan performance based specification contracts are used with the tire/pavement noise as a performance indicator. The tire/road noise is measured after the laying of the pavement and one year later. Shortly after the paving the noise level measured with the special test vehicle must not exceed 89 dB and after one year 90 dB. The tire/pavement noise is measured by a vehicle named “Road Acoustic Checker”. It is a CPX type measurement with a special tire placed at the rear of the vehicle and a microphone mounted close to the tire. The tire has a very special tread pattern with a 30 mm cylindrical hole and one-sided 25 mm wide lug grooves at a distance of 40 mm. This special tread pattern is claimed to enhance the difference between ordinary dense graded pavements and low noise pavements at frequencies around 1,000 Hz. The load of the test tire is 4.9 kN and the measurements are carried out at a speed of 50 km/h (+/- 0.5 km/h) due to the fact that porous asphalt is used for noise reducing purposes at this speed.

Measurements have been carried out on single and two-layer porous pavements. Single-layer pavements are 40 mm or 50 mm in thickness with maximum aggregate size below 5, 8, 10, or 13 mm. Two-layer pavements have a 20 mm top-layer with 5 or 8 mm maximum aggregate size, and a 30 mm bottom-layer with 10 or 13 mm maximum aggregate size. Measurements on 189 new pavements show a normal distribution of the noise levels with a mean level of 88.4 dB and a standard deviation of 0.58 dB. Only 5 % of the pavements exceeded the threshold level of 89.0 dB. After one year the mean level was 89.4 dB with a standard deviation of 0.52 dB. Also in year one only around 5 % of the pavements exceeded the threshold value of 90.0 dB. The general increase over the first year was 1 dB. The level for new pavements with 5 mm maximum aggregate was 87.9 dB, and this increased to 88.8 dB when the maximum aggregate size increased to 13 mm. The level for new single-layer porous pavements was 88.6 dB and for two-layers it was 88.1 dB. Results from long-term measurements have shown that the noise from the porous pavements increases by around 4 dB over a 5 years period.

In Japan performance based specification contracts have been tested since 1998 and comprehensive evaluation contracts since 1999. Both contract types include tire/pavement noise as a performance indicator but the comprehensive contracts include other factors than the price such as work plan, construction technique and safety. The total number of contracts in 2003 was 131.

Out of 190 performance based contracts, 189 were satisfactory and it is concluded that the contracts encouraging the use of advanced technologies in Japan. In Europe similar experiences with performance based contracts are being developed. If tire/pavement noise is included in the contract as a performance indicator it is crucial to have a sensitive standardized noise measurement method which is the case in Japan. The problem with such contracts only appears if the tire/pavement noise level is not satisfactory which has not been the case in Japan. Before implementing noise as a performance indicator into contracts in Europe a suitable measurement method should be implemented and accepted for a period of time. In Japan, one of the problems not being addressed so far in these contracts is how to ensure the acoustic durability of the pavements since there are only measurements after one year.

### **Function recovery and maintenance of porous pavements in Japan**

*Senior researcher Mr. Hiroshi MURAKAMI and Senior researcher Mr. Koyu SUZUKI, Road Management Technology Center (ROMANTEC), pavement research division*

*Chairman Yukiei MASUYAMA, Seikitokyu Kogyo Co. Ltd.*

Cleaning of porous pavements has been performed in Japan but it has been observed that the effect of the cleaning is not durable. The permeability is measured as the flow out time of water from a cylinder. Results indicate clogging of porous pavements on urban roads after 3-4 years. Different cleaning machines using high pressure water spraying has been developed since 1995. Some machines use water jet streams at an angle of 90 degrees to the road surface and others have water jets mounted on rotating devices. Measurements of noise reduction before and after cleaning on 4 to 6 years old pavements generally shows no change in the noise level after the cleaning with the first generation of cleaning machines.

With the first generation of cleaning machines, similar to machines used in Europe, the cleaning has to be carried out at very slow speed (1 km/h). Such low speeds reduce road capacity and creates traffic jams. New cleaning strategies have been developed with cleaning at higher speed (10-20 km/h) and more frequent cleaning (in some cases as often as once a week). Results from a national road in Tokyo indicate that this strategy is effective. The first generation machines are referred to as function recovery machines as they aim at recovering the function of a clogged porous pavement. The new cleaning machines are referred to as function maintenance machines as they aim at maintaining the function of the pavement noise reduction at all times.

In one of the new machines (Spec-keeper) water is sprayed on the pavement and at the edges of the sprayed area a "curtain" of high pressure air is established which pushes water out of the pavement enhancing the suction of the washing water. Dirt and particles are separated from the water and the water is recycled. Experiments indicate that

a better cleaning effect can be achieved and the working speed can be increased to 2-10 km/h. When the pavement is only partially clogged a working speed of 10 km/h can be used but for more densely clogged pavements the speed must be reduced to 2-5 km/h.

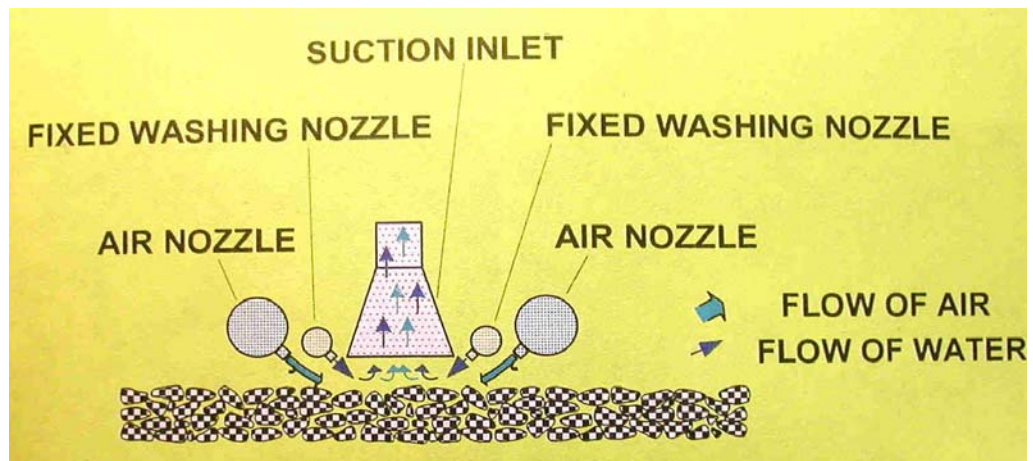

Figure 8. The principle of the function of the new Spec-keeper cleaning machine (photo of a slide from the presentation).

In another new machine only high pressure air is used (no water) combined with vacuum suction of the loosened dirt and dust. The working speed is 0-30 km/h with a stated average of 20 km/h. The air is blown from both sides of the pavement surface to be cleaned. In the middle of this area a suction system collects dirt and dust. Experiments with the machine has been carried out using cleaning frequencies of once a week, once a month, every second and third month and two times a year. The cleaning effect is monitored as the weight of material collected per square meter (or per operation). The conclusion is that cleaning should be repeated once a week to obtain the most effective function maintenance. An overview is effectiveness and costs of the three types of cleaning machines are given below (table from the presentation, 1 US\$ = 0.807 EUR).

Cleaning machine	Conventional type	High speed with high-pressure water	High pressure air blow
Collected mass/cycle (g/m <sup>2</sup> )	100	10	6
Frequency (times/year)	3	30	50
Cleaning costs (EUR/m <sup>2</sup> )	6.90	0.22	0.08
Cleaning costs (EUR/m <sup>2</sup> /year)	20.70	6.60	4.00

## **Porous elastic pavements**

*Senior researcher Dr. Seishi MEIARASHI, Material and geotechnical engineering research group, PWRI*

The porous elastic pavements are mixes of rubber chips and urethane binder (15 %). The aggregate size is 1-3 mm and the build in air voids up to 40 %. Fire tests indicate no severe risk compared to standard asphalt pavements. A 600 m long test section was completed on a national highway in Japan comparing different pavement types; single and two layer porous pavements and three types of porous elastic pavements with a thickness of 30 mm. Noise measurements has been conducted with a CPB type measurement. Traffic speed was 40, 50 and 60 km/h. The noise reduction for passenger cars was around 7-11 dB compared to a dense asphalt concrete and 5-8 dB for trucks. For single and two layer porous pavements noise reduction was 2-5 dB for trucks and 4-7 dB for passenger cars. The test track was removed after two years due to poor skid resistance. Skid resistance still needs to be improved and new tests are going to be performed on national highways. A 50 m long test section has been constructed already on a 60 km/h national two lane road and low traffic volume. A paper has been published in Applied Acoustics in 2005 [6].

So far the lifetime of the test sections has only been 6 month but it is believed that further developments could lead to a lifetime of 5-10 years which is the normal lifetime of pavements on heavy trafficked highways in Japan. Cleaning is not expected to be necessary as the void size is smaller than the clogging material. The rolling resistance has been measured and is the same as on ordinary pavements. The goal is to be able to lay the porous elastic pavements at the same speed as ordinary pavements. Today some of the porous elastic pavements are prefabricated slabs laid by hand and the price is at the moment around 200 Euro pr square meters which is almost the double of an equivalent noise barrier giving the same noise reduction. Though, the noise barrier only reduces the noise at low heights whereas the pavement reduces the noise at all positions. The recipes are confidential and are not published. For instance, in order to improve skid resistance small size artificial or natural aggregate is added but the exact composition of this material is not published. PWRI are planning to make a full scale test of porous elastic pavements on a highway with heavy traffic, and are at the moment negotiating with a road administration that are interested in this full scale experiment. Porous elastic pavements have also recently been laid by machines.

## **Structural durability of porous pavements in Japan**

*Researcher Dr. Osamu KAMADA, Road technology research group, PWRI*

The durability of porous pavements in Japan is generally the same as the durability of dense graded asphalt mixes but at the early stages several local damages are observed. These are potholes, ravelling, partial plastic flow and cracks. Damages are caused by poor quality of the porous asphalt, external factors such as wear by snow chains, abrasion loss in intersections or leaked oil from vehicles or caused by defects in the structure of the base course. Potholes are mainly caused by leaked oil from vehicles and defects in the base course by stripping due to insufficient sealing of the base course before the application of porous pavements.

The standard binder for porous asphalt mixes in Japan is a high viscous, 8 % SBS modified. The mixing temperature is 180 °C and the mix is compacted at 160 °C. One of the main reasons for poor quality of the porous pavement is presumably lack of compaction or low temperature during compaction. Ravelling is mainly observed in cold regions or intersections and caused by situations which are normally avoided in Europe (the use of snow chains, the use of porous asphalt in intersections). The counteractions for the early stage damages in the cold regions is to reduce air voids from 20 % to 17 % and to use a cold-weather high viscosity modified binder. Also, surface treatments “top-coat” has been applied in intersections. Examples of such treatments were given at NIPPO Corporation.

#### 4.4 Demonstrations at PRWI

##### Cleaning procedures for porous pavements in Japan

Two different cleaning machines were demonstrated at the PRWI test track as presented by *Senior researcher Hiroshi MURAKAMI and Senior researcher Koyu SUZUKI, Road Management Technology Center (ROMANTEC), pavement research division and Chairman Yukiei MASUYAMA, Seikitokyu Kogyo Co. Ltd.* Further information about these types of Japanese cleaning machines can be found in [4].



Figure 9. Cleaning machine using high pressure water.



Figure 10. Cleaning machine using high pressure air.



Figure 11. Inside the enclosure where the high pressure air cleaning is performed

### **Elastic porous pavements**

On the PWRI test track we inspected a 50 m long section with porous elastic pavement made of rubber granulate with an aggregate size of about 3 mm as presented by *Dr. Seishi MEIARASHI (PWRI)*. During the demonstration a passenger car passed the pavement. The noise level and frequency seemed very low and the high frequency air pumping noise was greatly reduced. In connection with the porous elastic pavement a standard 13 mm aggregate size porous pavement was constructed and even in comparison with this there was a significant noise reduction.



Figure 12. Test section with porous elastic pavement at the PWRI test track. The noise from a passenger car passing was very low and the high frequencies from air pumping noise were reduced significantly.

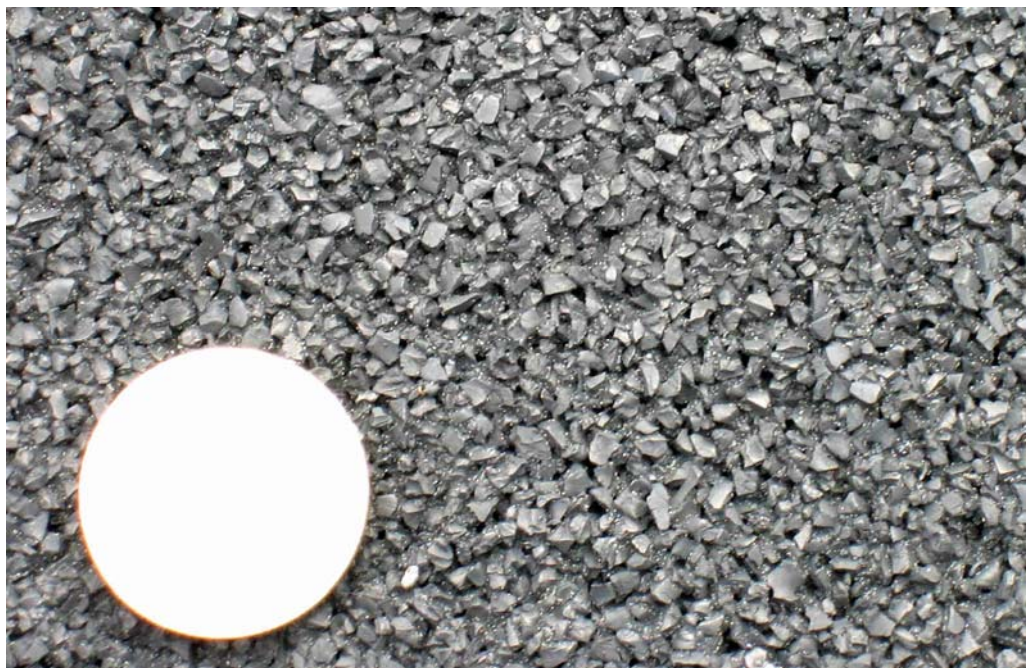

Figure 13. Close up of the pore elastic pavement made of granulated rubber with an aggregate size of 3 mm.

### **Active noise control**

On the PWRI test track there a 40 m long test section of a noise barrier with build in active noise control is present. The barrier has a height of 2.8 m and on top of the barrier a round devise is mounted with microphones that monitor the noise from the traffic. There is an automatic control system which from loudspeakers produces sound in



the phase opposite to the sound emitted from the vehicles. On a highway a 200 m long similar barrier was constructed some years ago. Measurements have shown that the extra effect of this active noise control is only around 1 dB. It was expected that the theoretical extra reduction would be as high as 10 dB.

The idea of using an onboard active noise control system in vehicles to reduce tyre road noise was discussed with a Japanese researcher. Such a system might be developed with microphones and loudspeakers placed near the contact area between tyre and road surface.



*Figure 14. Noise barrier with active noise reduction device at the top. The 2.8 m high barrier is situated at the PWRI test track.*

# 5. TOA DORO Road Construction Company

## 5.1 Highlights

- Different high viscosity modified binders are developed for general application, cold regions, steel decks and high ravelling and rutting resistance for use on heavy trafficked roads and intersections.
- Ravelling is tested at low temperatures in a linear wheel tracking device with snow chains mounted on the rubber wheel.
- The challenges of the future are to develop binder property tests related to the performance and accelerated binder aging tests that simulates the aging of the binder on the road.
- Two layer Porous Asphalt is laid by Multi-Asphalt Paver (MAP).

## 5.2 Introduction to TOA DORO

*Chief researcher Dr. Masato MURAYAMA, TOA DORO KOGYO Co. Ltd., Research laboratory*

TOA DORO is a construction company producing asphalt pavements and asphalt binders. The company also carries out other infrastructure works, e.g. foundation for the express train Shinkansen. The company was established in 1930 and they have 1280 employees. They have 24 asphalt plants through out Japan. We visited the central laboratory with 40 researchers organized in five groups, and a group of 20 researchers are developing hot asphalt mixtures and binders. They also focus on developing noise reducing pavements.

## 5.3 Development of porous asphalt in Japan

The history of porous asphalt mixes in Japan was presented by *Dr. Masato MURAYAMA*. The first test tracks were constructed in Tokyo 1987 and in 1988 a scanning tour in Europe was conducted. A high viscosity binder was developed in Japan in 1989 and was applied on an expressway in Niigata. The first manual on porous pavements was published by the Japan asphalt association in 1996. In 1998 high viscosity bitumen to be used in cold areas was developed. The use of high viscosity bitumen has been increasing since 1996. Different binders are developed for general use and special products are available for small size aggregate in top layers, for intersections and for cold and very cold areas as well as for steel decks. A binder bending testing device has been developed testing the flexibility of the binder at low temperatures (-20 °C).

## 5.4 Durability of porous pavements

The durability of porous pavements is tested by Cantabro test and wheel tracking tests. Wheel tracking test is performed in the laboratory on rotating pavement slabs (300 by 300 mm) compacted in the laboratory. The deformation created in the pavement slab by the wheel is the measure of the durability of the mix. Ravelling is not observed during this test as it is performed at a rather high temperature. Ravelling is tested at low temperatures (-10 °C) in a linear wheel tracking device with snow chains mounted on the rubber wheel. Permeability is tested in laboratory on Marshall samples and on site

measuring the run out time of water from a tube and from visual inspections of drainage of water sprayed on the newly laid pavement.

### **5.5 Asphalt pavers**

The company has developed the Multi-Asphalt Paver (MAP) a laying machine that can lay two layer porous pavements in one application using the warm in warm process. They are producing a two layer porous pavement with 5 mm maximum aggregate size at the top layer and a thickness of 15-20 mm. The bottom layer has a thickness of 30 mm and a maximum aggregate size of 13 mm. The top layer has an air void content of 23-25 % and the bottom layer 20 %. 5 % of limestone is added to the porous mix.

TOA DORO also presented the POSMAC (porous surface mastic asphalt course) paver sprays an asphalt emulsion and a braking agent in the same process as laying the porous pavement in order to create a membrane on top of the base course. This process is similar to the French thin layer pavements (combination pavements).

### **5.6 High performance binders**

The traffic volume on highways in Japan is very high and high durability therefore is required. At the same time Japan has large variations in pavement temperatures with surface temperatures between -30 to + 60 degrees. The crude oil is imported from the Middle East and the quality and properties of the bitumen is varying. SBS modification is used. By increasing the SBS quantity the performance of the pavement can be improved. The registered trademark of the TOA DORO binder is PERMI-BINDER and it is marketed in different special versions for cold regions, steel decks and high ravelling and rutting resistance for use on heavy trafficked roads and intersections. The challenges of the future are to develop binder property tests related to the performance and accelerated binder aging tests that simulates the aging of the binder on the road. Equipment to perform those tests might include DSR and BBR.



Figure 15. Test sections with porous asphalt. The pavement at the bottom of the picture is painted in a light colour in order to make the pavement reflect the light and heat of the sun in order to reduce the temperature of the pavement in sunny periods. This can prevent rutting of the pavement and reduce temperatures for pedestrians in urban areas.



Figure 16. The rotating pavement durability tester.



Figure 17. Pavement slaps produced at the laboratory after it is tested in the wheel tracking device.



Figure 18. Durability tester with steel chains mounted on the wheel in order to simulate the effect of raveling from snow chains in cold regions. This test is performed at minus 10 °C.



Figure 19. Different binder types produced by TOA DORO.



Figure 20. Model of the Muti-Asphalt Layer Machine (MAP) that can apply two layer pavements in a warm in warm process.

## 6. NIPPO Road Construction Company

### 6.1 Highlights

- Two layer Porous Asphalt is laid by using a Double Layer Paver.
- Advanced materials are used to increase durability (Top Coat and Permeable Resin Mortar System).
- Cleaning by using a water jet (Tornado) is more cost effective than traditional cleaners.
- Porous pavements are used on high traffic urban roads in Yokohama, also at bus stops and intersections.

### 6.2 Introduction to NIPPO

*General manager Mr. Masao WATANABE, NIPPO Corporation*

*Manager Mr. Hidetoshi IZUMI, NIPPO Corporation, Technical development*

Nippo road Construction Company is the largest road construction company in Japan with a capital of 15.3 billion yen and activities within paving, architecture, development and civil works. It was established in 1934 and the number of employee is 2,625. We visited the central research and development centre in Tokyo.

### 6.3 Doble layer paving machine

The company is using a Double Layer Paver (DL Paver) which can lay two layer porous pavements in one application as a warm in warm process. The machine is produced by the WIRTGEN Company in Japan and so far four machines have been produced in Japan. A similar but larger machine is manufactured by the BAM Company in Europe and it has been used in the outskirts of Amsterdam in the Netherlands.

The paving machine is equipped with large hoppers so it can pave without stopping while trucks are replaced. (Hopper for upper layer around 5 m<sup>3</sup> and for bottom layer around 8 m<sup>3</sup>). The pavers can be loaded with asphalt material delivered by trucks using a special conveyer belt system. Each screed of the paver has an automatic pavement thickness control. The machine is equipped with a special spring system which makes it possible to pave as the machine passes manholes. The paving width is between 2.5 and 4.75 m and the speed of paving is 4-5 m per minute. The devices used for the second layer can be dismantled so the machine can be used to lay ordinary one layer pavements.

The integration of the top and the bottom layer in one laying process improves the durability of the pavement because the tensile strength between the two layers is improved. The process also reduces construction time and costs significantly and by this the disruption to road users. Normally the paving is performed at night in order to reduce the disturbance of traffic flow. The mixing temperature is 180 °C and paving temperature 160 °C. A high mix and paving temperature is needed because of the use of high viscosity modified binders. The temperature of the asphalt material is checked manually during paving. The temperature of the newly laid pavement is measured in order to decide when the newly paved road section can be opened for ordinary traffic.

The permeability of the newly laid pavement is checked by the falling water head method (Becker like equipment). The company highlighted that porous pavements improves traffic safety in rainy periods. Further information about this type of Japanese paving machine can be found in [4].

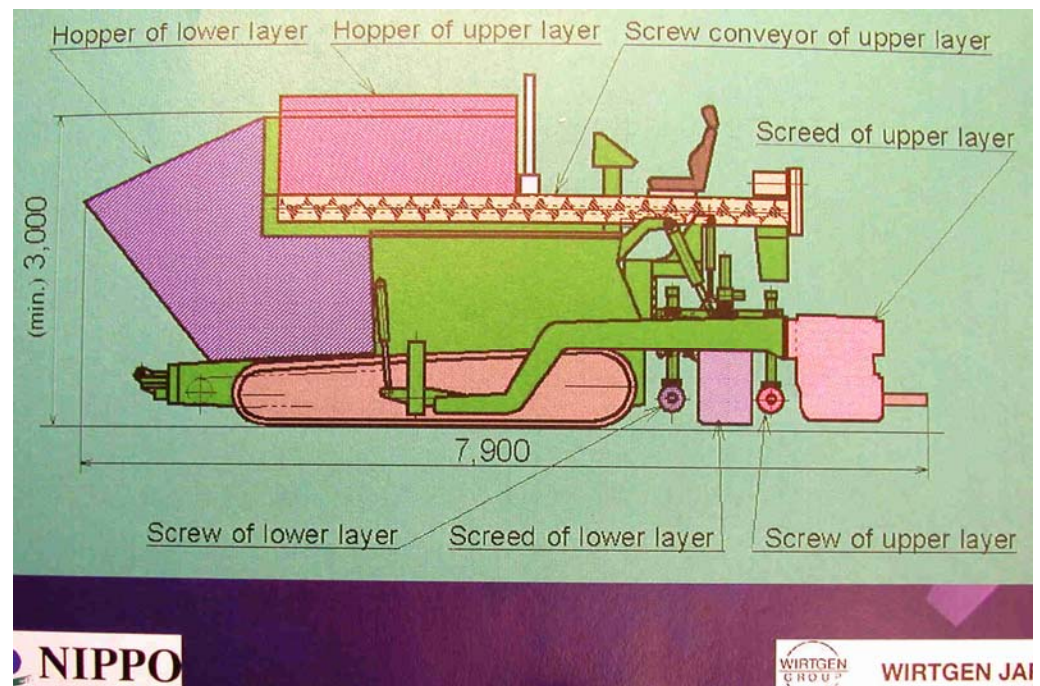

Figure 21. Photo copied from a NIPPO presentation of the machine that can lay two layer porous pavements in one process.

#### 6.4 Noise reducing pavements

Some results of noise measurements on porous pavements with 5, 10 and 13 mm maximum aggregate size in the top layer showed an increase in noise by 1.0 to 1.5 dB, when the aggregate size was increased from 5 to 13 mm. Normally 13 mm aggregate is used for the bottom layer of porous pavements. The pavement is produced in a thin version with 20 mm upper layer and 30 mm bottom layer and in a thick version with 30 mm top layer and 70 mm bottom layer.

NIPPO produces a thin layer pavement with 5 mm aggregate size that reduces noise. This type has been used for 10 years. Thin layer pavements are produced with special pavers having spraying systems for bitumen emulsion sprayed in front of the paver. The emulsion has been improved so they now only use 0.4 litres per square meter.

#### 6.5 High performance surface treatments

Permeable Resin Mortar System (PERMS) is a resin mortar with fine (porous) ceramic material (aggregate size 1.5 mm) that is applied as a surface treatment on porous pavement. The mortar fills the voids but keeps permeability (only approximately 10 % loss), the treatment prevents ravelling and further clogging of the pavement and cleaning is not necessary. The resin used is epoxy and the material is spread manually and can be produced in different colours (black, white, brown, yellow, green and blue). The epoxy consists of base resin and hardening agent. There are two types of epoxy



resin; one for the summer season (minimum 10 minutes working time) and another for the winter season (minimum working time 7 minutes) when the average ambient temperature is below 15 °C. Most often the resin for the winter season is used as the application time before opening then decreases. The tensile Strength is minimum 20 N/mm<sup>2</sup> and the tensile elongation minimum 50 %. Standard ratio of ceramic aggregate to epoxy resin is 86 to 14 when the black aggregate is used. The skid resistance is the same or better than for porous asphalt. The product was developed 6 years ago and 300.000 square meters have been applied so far. The product has mainly been used in intersections on urban roads in order to improve shear resistance. 500 square meter pr day can be applied. The noise reduction should be improved by up to 5 dB compared to normal porous pavement due to the fine texture of the treatment. The price is 28 Euro pr square meter. The standard price of porous asphalt is in comparison 14 Euro per square meters.

**Gradation of ceramic aggregates is as follows:**

Sieve Size	Weight Passing
1.7 mm	100 %
1.0 mm	70 % (minimum))
0.5 mm	35 % (maximum)
0.15 mm	3 % (maximum)



*Figure 22. Read version of Permeable Resin Mortar System (PERMS) is a resin mortar with fine (porous) ceramic material (aggregate size 1.5 mm) that is applied as a surface treatment on porous pavement.*

Another product is marketed as “Top Coat” that can be applied to porous pavements for the same purpose as PERMS except to reduce tire noise. Methyl-Methacrylic (MMA ) resin is mainly used for this treatment. The resin is sprayed two times, the first application rate is 0.4 to 0.7 kg per square meter, and the second application 0.3

to 0.5 kg per square meter. Fine silica sand (0.3 to 0.5 kg per square meter) is scattered after each application to increase skid resistance. The aim is to coat the upper two stones in the pavement structure. It takes about 30 minutes before the resin hardens completely. The second application should be sprayed after the first application has hardened. If the treatment is applied on the same day as the hot-mix pavement, this should wait until the pavement temperature is below 50 °C. It is claimed that the porosity of the porous pavement will not be changed. This sealing should reduce raveling and improve skid resistance and can also be produced in different colours. 1,500,000 square meters have been applied across Japan as of the end of 2004.

### 6.6 New cleaning machines

NIPPO also develops and uses cleaning machines for porous pavements. The most recent developed machine is called Tornado. The working principle is to spray water under high pressure (19 MPa at the nozzles) on the pavement at an angle of 45 degrees and suck up water and dirt. Water is sprayed in front and behind the section of suction. The cleaning process takes place in a space enclosed by rubber and steel skirts. The operation speed is 6 to 10 km/h. Sections of a width of 2.0 m can be cleaned. Measurements of permeability have shown that the run out time of water can increase up to 50 % after cleaning.

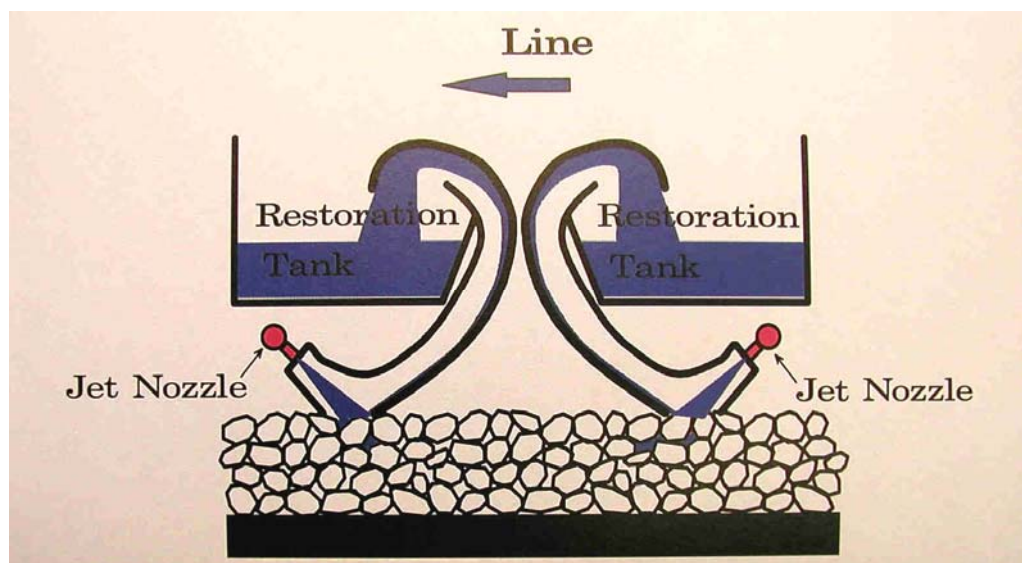

Figure 23. The principle of the Tornado cleaning machine. Water under high pressure is sprayed on the pavement at an angle of 45 degrees (photo of a slide from the presentation).

Another cleaning machine works with rotating nozzles and suction of water and dirt. The cleaning process is carried out in a space enclosed by rubber skirts. Some data presented indicated that carrying out more cleanings per year improves the permeability of porous pavements.

### 6.7 Site inspection in Yokohama

The NIPPO Company has paved some road sections with two layer porous pavements on main roads in Yokohama. The aggregate at the top layer has a maximum aggregate size of 8 mm and the pavement was 20 mm in thickness. The bottom layer has a

maximum aggregate size of 13 mm and was 30 mm thick. A high viscosity modified binder is used. The binder content is 5.9 % in the top layer and 4.7 % at the bottom layer. The build in air void measured on Marshal samples is 24.8 % in the top layer and 22.8 % at the bottom layer. The steep gradation of the asphalt mixes can be seen in Figure 24.

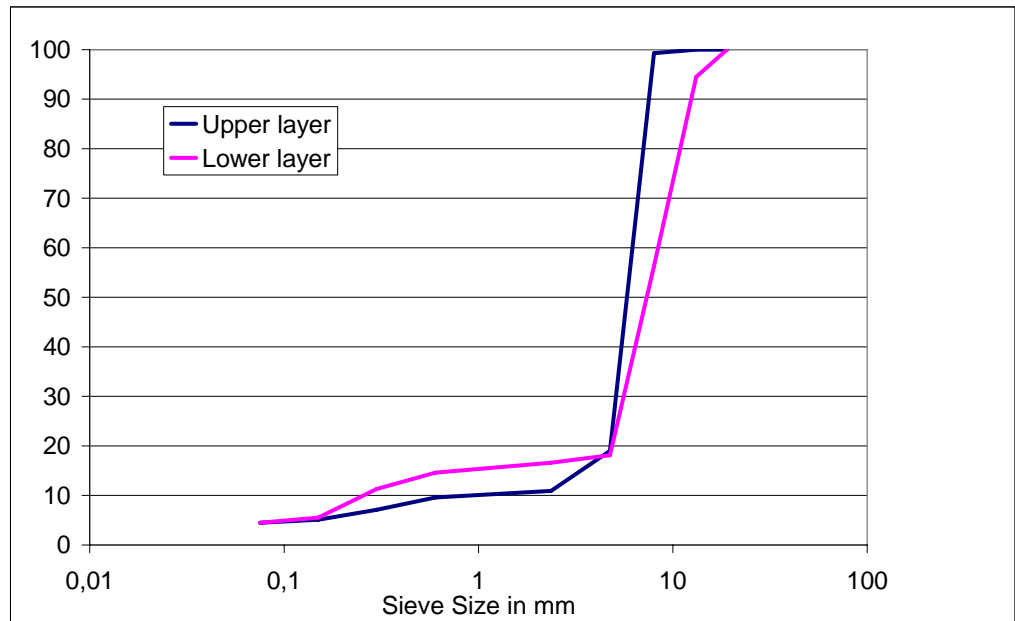

Figure 24. Gradation curves of the top and bottom layer of the two layer porous asphalt in Yokohama.

There are kerbstones along the road so water can not run from the pavement structure to the surroundings. In order to drain the water penetrating the porous pavement from the subbase another 50 mm thick layer of 13 mm porous pavement has been laid at the roadside. At the bottom of this layer a drain tube is laid. The drain tube will lead the water to the gullies along the road. See Figure 25. The speed limit of these roads was 60 km/h.

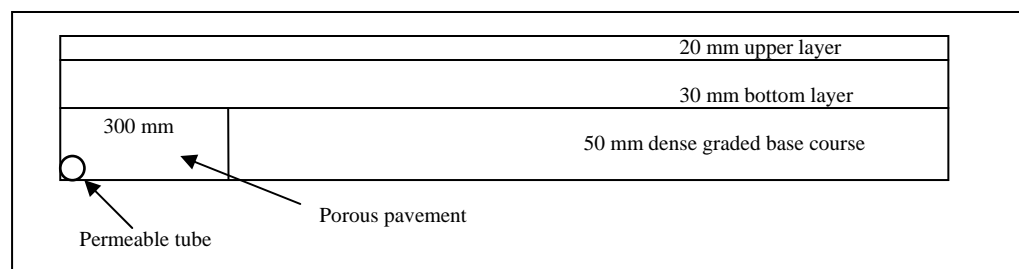

Figure 25. The system leading rain water from the porous pavement structure to the gullies.



Figure 26. Highway with one year old two layer porous asphalt in Yokohama.



Figure 27. Close up of two layer porous pavement with 8 mm aggregate in the top layer in Yokohama.



*Figure 28. In an intersection part of the porous pavement was treated with the NIPPO product "Top Coat" in order to prevent ravelling caused by turning vehicles (left part of the pavement).*



*Figure 29. Local areas with ravelling on a new porous pavement in Yokohama.*



*Figure 30. Porous pavement used at an intersection in Yokohama.*

# 7. Civil Engineering Research Institute of Hokkaido (CERI)

## 7.1 Highlights

- The noise problems on Hokkaido Island are less severe than in the central parts of Japan. The main reason for using porous pavements is traffic safety.
- Special conditions for pavement construction and maintenance exist on Hokkaido due to the cold, snowy climate. Structural damage of porous asphalt is a serious problem in cold regions. Snow removal operations cause severe damage; rutting and ravelling occurs after a few years.
- A new type of hybrid pavements has been developed. These hybrid pavements are constructed as a hybrid of stone mastic asphalt (SMA) and porous pavements and can much better withstand the exposure to snow removal operations.
- High viscosity modified binders for cold regions has been developed and research demonstrated better durability using a high durability, high viscosity modified binder than with conventional high viscosity modified binders.
- CERI has investigated how to improve the permeability performance by increasing the voids from 17 % to 20 % or even 23 %.

## 7.2 Introduction to CERI

On Thursday the 17th of November we visited colleagues at the Civil Engineering Research Institute of Hokkaido (CERI). It is a private research institute with a total of 173 employees out of which 109 are researchers. The institute was privatised in 2001. It has a road research division that specially focuses on road construction and management in cold regions as well as recycling. This division also conducts projects on noise abatement. They do not have their own noise measurement equipment but use consulting companies. Noise measurements are often performed with the Japanese CPX like system with very special tyre (called the RAC vehicle). There are five calibrated measurement vehicles like the RAC vehicle in Japan. The institute rents such a vehicle to perform measurements.

CERI has a 2,700 m long test track that can be used for experiments with pavements and vehicles driving during different winter conditions. Most of the revenue used by the institute comes from the government and all the shares are owned by the government. The institute is aiming towards increasing funding from other clients.

Representatives from the East Nippon Expressway Company gave presentations during the meeting and later we inspected road sections on the expressway network in Hokkaido. The East Nippon Expressway Company has the responsibility to maintain and develop the highway network in the north eastern part of Japan including the Hokkaido Island. It was originally a part of the public government administration but in 2004 it was privatised. The revenue comes from the collection of road toll which also has to cover investments in new road constructions. The company operates 2,250 km of expressway and about 500 km are under construction. On the Hokkaido Island they operate 593 km of expressway and have 159 km under construction.

The population on the Hokkaido Island is 5.6 millions and the island is much less densely populated than the rest of Japan. Therefore, the noise problems are less severe than in the central parts of Japan.

### **7.3 Presentations at CERI**

The Dutch – Danish delegation was welcomed to Civil Engineering Research Institute of Hokkaido (CERI) by *Director of maintenance and management division Mr. Jun TAKO* who presented the primary tasks of the institute. He explained the special conditions for pavement construction and maintenance at Hokkaido due to the cold, snowy climate.

#### **East Nippon Expressway Co. Ltd.**

*Engineer Mr. Masaru MIYAKE, East Nippon expressway co. ltd.*

The Hokkaido Island is a cold region with a long and cold winter season. The annual snowfall in Sapporo is 5 m pr. year and the average temperature in January is  $-5^{\circ}\text{C}$ . Some regions on Hokkaido has colder climate and up to nearly 10 m of snow. As a comparison Stockholm has also minus  $5^{\circ}\text{C}$  in January but only 2 m of snow. Munich in Germany has  $-3^{\circ}\text{C}$  and 1 m of snow and Helsinki in Finland  $-8^{\circ}\text{C}$  and also 1 m snow. These data indicates that Hokkaido is a colder region with much more snow fall than both The Netherlands and Denmark.

Winter maintenance is carried out by spreading wet salt and by the use of snow ploughs. Sometimes ice on the pavements has to be removed by the snow ploughs. Therefore the ploughs are equipped with steel and not hard rubber under the scraper, because the use of rubber scrapers would reduce the effect of removing ice. Rotary snow removers are also used to widen the driving lanes in periods with very large amounts of snow along the road sides.



Figure 31. Heavy snow moving material with steel plough used in the Hokkaido road districts.





Figure 32. Rotary snow remover.

Studded tires have been used in the Hokkaido area in order to reduce traffic accidents. But from 1985 the use of studded tyres has gradually been reduced. The use has been prohibited from 1990 and now only snow chains are used.

The use of porous asphalt started in 1999 mainly in and around urban areas. Only 1 % of the national roads are covered by porous pavements but 50 % of the expressways are and the use of porous asphalt is increasing. The problems maintaining porous pavements have appeared and work has been undertaken to develop appropriate winter maintenance methods.

The main purpose of using porous pavements is to improve traffic safety basically during rainfall but also in dry periods because the skid resistance of porous pavements is higher than for dense pavements. Therefore the porous pavements are also used on highways in rural areas. In populated areas it is at the same time an aim to reduce noise but as there are only few residential areas along the Hokkaido highways noise is not a decisive for the use of porous pavements.

Structural damage of porous asphalt is a serious problem in cold regions. The number of snow removal operations on a road can vary between 150 and 300 times a year and this causes severe damage in the porous asphalt. Rutting and ravelling occurs after a few years. Some data showed that an initial thickness of 40 mm of a porous pavement was reduced to 5 mm in the wheel tracks and 24 mm between the wheel tracks, basically because of the use of snow ploughs with steel scrapers. At the road side loose aggregates can be found in significant quantities. Partial repair works with dense asphalt are conducted on the most damaged spots.

Noise measurements (presumably SPB measurements) have demonstrated noise levels around 71 to 72 dB for new porous pavements. The noise on dense asphalt pavements varies between 72 and 74 dB. Due to the loss of aggregate the noise level of porous pavements increases over time. For a 1-2 years old porous pavements the noise level is 74 to 75 dB and after 3-5 year around 76 dB.

It has been a challenge in the Hokkaido area to develop pavement types effectively reducing splash and spray with high skid resistance and at the same time a high structural resistance to the wear of snow ploughs. A new type of hybrid pavements has been developed. These hybrid pavements are constructed as a hybrid of stone mastic asphalt (SMA) and porous pavements. The mix is dense with a very open surface texture in the upper 10-13 mm equivalent to the maximum aggregate size. The binder used is not a high viscosity binder but a standard SBS modified binder. The hybrid pavement is laid by an ordinary asphalt paver in one pass and the mix requires severe quality control during production as it is quite sensitive to the amount of mortar. Bleeding during compactions is often observed. The hybrid pavement has a gradation curve in-between porous pavement and SMA (see Figure 33) and during construction care must be taken to prevent bleeding.

These hybrid pavements can much better withstand the exposure to snow removal operations. Experiments have shown that at locations where the thickness of porous pavements was reduced 3.1 mm by snow ploughs the thickness of hybrid pavements was unchanged. The hybrid pavements are new and the practical experiences therefore still are limited. The durability has been tested by the Cantabro Test at low temperatures (- 20 °C). The particle loss for hybrid pavements was 26.5 % compared to 46.1 % for porous asphalt.

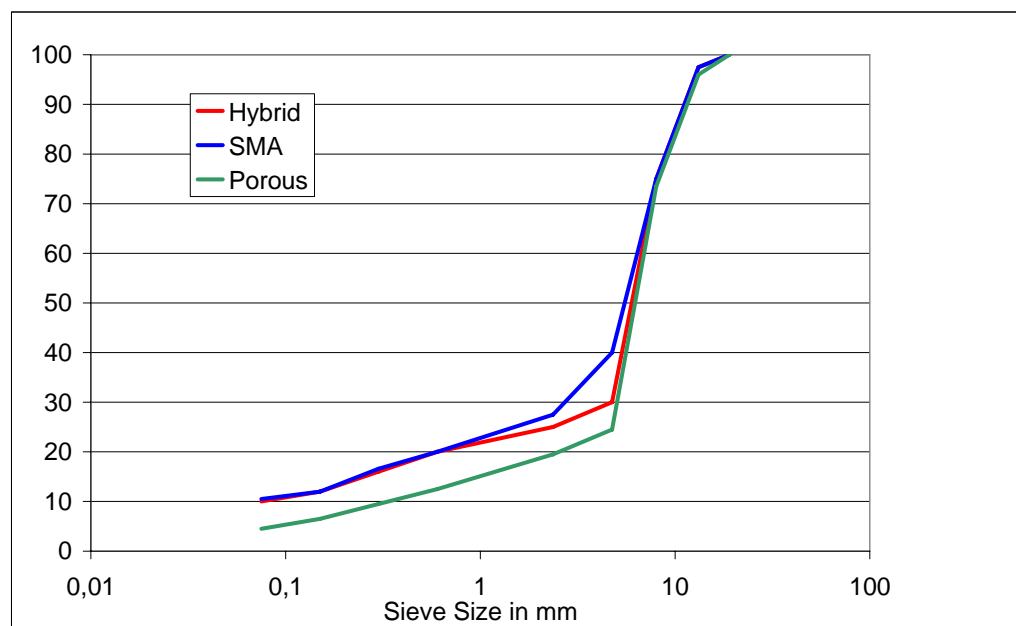

Figure 33. Material gradation curves for porous pavements, new hybrid pavement and SMA pavements.

By visual inspection the splash and spray behaviour of porous pavements and hybrid pavements seems to be relatively identical but our Japanese colleagues in Sapporo did not have any objective measurements of the level of splash and spray. The new pavement strategy is to use the hybrid pavement generally on express ways and only to use porous pavements where the rate of traffic accidents is high. It is also a goal to investigate and optimise the snow removal methods in order to reduce the damages on pavements.

### **Improving the performance of porous pavements**

*Researcher Mr. Manabu CHIBA (CERI)*

Porous pavements are mainly installed on expressways for traffic safety reasons to prevent hydroplaning and on urban roads also to reduce noise. In cold regions the performance of porous pavements is poor mainly due to the use of snow chains. CERI has investigated how to improve the permeability performance by increasing the voids from 17 % to 20 % or even 23 %. The standard particle loss by low temperature Cantabro test (-20°C) is 20 % and this is met by porous mixes with 17 % voids and a high viscosity modified binder. Increasing the voids to 20 % increases the particle loss to 22.5 % (above the standard) and therefore it was necessary to develop a high viscosity modified binder for cold regions (for instance the Permi-Binder F from TOA DORO). The new 20 % void mix demonstrated improved noise reduction by using the Road Acoustic Checker (RAC) vehicle.

Two further tests were performed in the durability study: The torsion resistance test at 60 °C with a pneumatic tire rotating at 5 rpm and rotating the test slab at 10 rpm and the reciprocating chain ravelling test (as demonstrated at TOA DORO). The research demonstrated better durability using a high durability, high viscosity modified binder than with conventional high viscosity modified binders. It was even considered to increase the voids ratio to 23 %. CERI did not have any details about the new binder which was delivered by Taisei Rotec Corporation. CERI supplied the Dutch-Danish delegation with contacts details.

### **Effectiveness of porous pavements against skidding on winter roads**

*Researcher Mr. Manabu CHIBA (CERI)*

The friction coefficient was measured by a special vehicle on a test track with the same amount of water sprayed on different pavement types exposed to freezing. On porous pavements the water mainly drains down in the pavement structure whereas it runs off on the surface of dense pavements. These experiments demonstrate nearly the same friction coefficient for porous pavements with 17 and 20 % built in air void (around 0.86 to 0.90) in an artificially created black ice condition. For the newly developed hybrid pavements the friction coefficient is only half (0.43) of porous pavements and for conventional dense pavements it is 0.18. In situations with ice on the surface the pavements perform identically with a low skid resistance around 0.15 to 0.19. In situations with compacted snow the skid resistance is also identical for the three different pavement types but better than on ice (0.31 to 0.41). On this experimental background it was concluded that porous pavements are more effective in reducing slipping on roads with black ice better than ordinary dense pavements. Though, it is

questionable if these experiments reflect the real black ice situation where the ice presumably is formed on the surface of porous pavements.

### **Using materials recycled from porous pavements**

*Senior research engineer Mr. Ryuji ABE (CERI)*

Porous pavements with highly modified binders are used on the Hokkaido highways. Variations in the properties of recycled aggregates from porous pavements due to the high content of modifiers could cause poor quality of new mixes with recycled aggregates. Research has been performed to see if it is possible to control these variations. It is suggested to degrade the binder to a penetration of 20 before mixing with new material and testing for various properties. The reclaimed, degraded binder was mixed with a rejuvenator to obtain a penetration of 80-100 and then mixed with new straight bitumen of the same penetration. The recycled binder showed higher softening point, lower ductility and lower embrittlement point than the new binder. Dense graded asphalt mixes was prepared from straight bitumen mixed with recycled binder and 20 % or 50 % recycled aggregate. The properties of the recycled asphalt mix was similar to new mixes but showed lower stress relaxation and improved fatigue resistance.

In the future construction of roads with recycled materials will be performed. So far CERI does not have experiences in recycling porous pavements on site and specifically no experience in the construction of porous pavements from recycled porous pavements.

### **Winter maintenance**

*Deputy Director of maintenance and management division Mr. Tateki ISHIDA (CERI)*

As presented by *Mr. Masaru MIYAKE* the Hokkaido Island is a cold region with a long and cold winter season. The annual snowfall in Sapporo is 5 m pr year and the average temperature in January is -5 °C. Some regions on Hokkaido has colder climate and up to nearly 10 m of snow. In Hokkaido a white surface policy has been implemented with 24 hour operation on main trunk roads and snow dumping in urban areas two or three times a year. The scattering of de-icing agents and sand has increased since 1990 when studded tires were prohibited. The intensive use of snow ploughs and snow chains has lead to a short lifetime of porous pavements as stated earlier.

## **7.4 Site inspection East Nippon Expressway Company**

### **Highway north of Mikasa**

We inspected a site on a highway 2 km north of Mikasa on Hokkaido Island with a one year old porous and hybrid pavement both with 13 mm maximum aggregate size and a thickness of 50 mm. Both pavements were in a good condition even though there was a tendency towards bleeding in the wheel tracks of the heavy lane of the hybrid pavement. Visually the hybrid pavement seemed to have a very open surface texture with cavities having a depth up to the aggregate size of 13 mm (see Figure 35).

Passenger cars passing from the porous pavement to the hybrid pavement revealed a slight increase in the high frequency noise on the hybrid pavement compared to po-

rous pavements, indicating that this pavement do not reduce the air pumping noise as much as the porous pavement.



Figure 34. Highway 2 km north of Mikasa on Hokkaido Island with one year old porous and hybrid pavements with 13 mm maximum aggregate and a thickness of 50 mm.



Figure 35. Close up of the porous (to the right) and the hybrid pavements both with 13 mm aggregate.



Figure 36. There was a tendency for bleeding of bitumen/mortar in the wheel tracks of the heavy driving lane of the hybrid pavement.

### **Porous pavements for urban roads**

In Sapporo we inspected a new two layer porous pavement. At urban roads porous pavements are used to reduce noise. Measurements have been carried out over some years (presumably using the Japanese CPX like system, the Road Acoustic Checker (RAC)). A good initial noise reduction of 4 to 6 dB disappears over 2 to 3 years because of clogging. Measurements have shown that a high initial permeability is gone after 2 years.

In order to improve durability the built in air void has been increased from 17 to 20 %. A special high viscosity modified binder for cold regions has been developed. Permeability has been measured on porous pavements with 17 and 20 % built-in air voids. The results demonstrate best permeability of the 20 % voids pavements and the permeability is maintained over a longer period. Noise measurements have been performed on new porous pavements with 20 % air voids and they have nearly the same initial noise reduction as those with 17 % air voids, but after three years the noise level is about 2 dB lower for pavements with 20 % air voids. In the future new porous pavements for cold regions with 23 % built in air voids will be developed and tested as presented by *Mr. Manabu CHIBA* in the morning.

## 8. Greater Tokyo area

During our visit to Tokyo we had a meeting with Professor Shigeo IWAI from College of sci-ence & technology at the Nihon University. With him we inspected some porous pavements on urban roads in the Tokyo area.



Figure 37. Porous pavement on a main road near the Emperors Palace in Tokyo with a driving speed of around 50 km/h. The porous pavement was also used at the adjacent intersections.



Figure 38. 30 km long new ring road in Tokyo area constructed with tall noise barriers bending over the road.



Figure 39. In the densely populated Tokyo area noise barriers are very common on the highway network.

The effect on traffic safety of using porous pavements has been studied in various Japanese surveys. In an article presented at the 3rd Eurasphalt & Eurobitumen Congress in Vienna 2004 some results are presented [6]. Porous pavements have a positive effect on traffic safety and this in combination with drivers comfort is important reasons for using porous pavements in Japan. There is a special focus on accidents under wet driving conditions. On a part of the Japanese highway network with dense asphalt the number of traffic accidents under wet driving conditions has been monitored. 2981 accidents per year were recorded. After the re-placement of the dense asphalt by porous pavement the number of accidents was reduced to 488 accidents per year. This is a reduction of more than 85 % under wet driving conditions.

In another survey the number of traffic accidents on a main road was studied one year before and one year after the construction of a porous pavement. Before the construction the yearly level of traffic accidents was 248 and it has been reduced to 206 with porous pavements. There was no change in the accident rate under dry pavement conditions. The change occurred under wet pavement conditions where the number of accidents was reduced from 76 to 36. With the old “normal” pavement 31 % of the accidents occurred under wet driving conditions, and this was reduced to 18 % with the porous pavement. The reduction of traffic accidents under wet pavement conditions was higher at daytime than at night time. Analyses of the individual accident show that the main reason for the reduction of accidents was a reduction of slippery road conditions. The reduction of traffic accidents was higher for passenger cars than for trucks.



## 9. Conclusions

Japan is a densely populated country with an intensively built-up road infrastructure. Due to a general lack of vacant land highways and main roads are often constructed very close to urban and residential areas. This creates problems with noise from road traffic and therefore noise abatement and research and development in new and improved technologies that may reduce noise effectively have a high priority in Japan.

Porous pavements are used on both highways and urban roads in Japan. There is a series of reasons for using porous pavements in Japan:

1. To improve the traffic safety by improving skid resistance.
2. To improve the traffic safety and comfort for drivers and pedestrians in rainy periods by leading the water from the pavement surface thereby reducing splash and spray.
3. To reduce the risk of flooding in periods with heavy rainfall by leading water from the pavement surface to the gullies and to the subbase.
4. To improve the microclimate in cities during night time by retaining rain giving a slower evaporation of water from the road surface and by this reducing the temperature.
5. To reduce traffic noise.

Porous pavements are widely used in Japan both on highways and in urban areas. Today the total area of porous pavements is 50 million m<sup>2</sup> and it is still increasing. On toll roads more than 50 % of the pavement is porous. The structural durability of porous pavements in Japan is generally the same as the durability of dense graded asphalt mixes. In the warm regions the structural durability of porous pavements is 10 years or more, and in the cold regions 7-10 years. Structural damage of porous asphalt is a serious problem in cold regions. Snow removal operations by snowploughs causes severe damage in the porous asphalt and rutting and ravelling occurs after a few years. This has led to use of high viscous SBS modified binders in the cold regions and to the development of a 'hybrid' pavement with a dense structure and an open surface texture.

Most pavements are single layer pavements with 13 mm maximum aggregate size, 20 % built-in air voids and high viscosity 8 % SBS modified bitumen. In cold regions pavements with 17 % built-in air voids are constructed. Porous pavements are used in urban areas even at intersections and bus stops, and on highways in the countryside. At some intersections a special epoxy based surface treatment is applied in order to improve durability. Tests with two layer porous pavements started in 1998 and are mainly used on urban roads. The driving speed is in general low (below 50 – 60 km/h in urban areas and 100 km/h on highways).

The application of two layer porous pavements in one application as a warm in warm process is widely used in Japan. A compact machine is produced by the WIRTGEN

Company in Japan and a similar but larger machine is manufactured by the BAM Company in Europe. The integration of the top and the bottom layer in one laying process improves the durability of the pavement and construction time, costs and disruption to road users are reduced significantly.

In Japan performance based specification contracts are including tire/pavement noise as a performance indicator. The tire/road noise is measured after paving and one year later using a special Japanese CPX-method (close proximity method). Shortly after the laying the noise level measured must not exceed 89 dB and after one year 90 dB. The average level for new single layer porous pavements was 88.6 dB, and for new two layers porous pavements 88.1 dB. As a reference a 13 mm maximum aggregate size dense asphalt concrete are usually used. For single and two layer porous pavements noise reduction was 2-5 dB for trucks and 4-7 dB for passenger cars. The highest reductions are obtained on two layer porous pavements. Results from long-term measurements have shown that traffic noise from the porous pavements increases by around 4 dB over a 5 years period.

New cleaning strategies have been developed with cleaning at higher speed (10-20 km/h) and more frequent cleaning (up to once a week). The vacuum cleaning machines uses high pressure water and air pressure curtains or only high pressure air. The first generation machines are referred to as function recovery machines as they aim at recovering the function of a clogged porous pavement. The new cleaning machines are referred to as function maintenance machines as they aim at maintaining the function of the pavement at all times.

Porous elastic pavements are under development and full scale testing in Japan. These pavements are very effective noise reducing pavements, but the price is high and an acceptable lifetime has still to be proven. The noise reduction for passenger cars was 7-11 dB and 5-8 dB for trucks compared to a dense asphalt concrete. It is believed that further developments could lead to a lifetime of 5-10 years. The detailed recipes are confidential and are not published.

Porous pavements have proven to increase traffic safety in Japan.

In Japan new futuristic approaches is under development such as:

- Noise barriers with active noise control.
- New Air Void Assessment Technology.
- Vehicles with active noise control towards tire/road noise.

## 10. References

- [1] The DRI-DWW Noise Abatement Program - Project description. Note 24, 2005. Danish Road Institute, Road Directorate ([www.roadinstitute.dk](http://www.roadinstitute.dk)).
- [2] Noise Innovation Program. Road Traffic. (The IPG programme). DWW report 2002-073.
- [3] Sandberg, Ulf and Kalman, Björn. Study Tour to Japan 2001 – Poroelastic Road Surfaces and Noise Barriers. Swedish National Road and Transport Research Institute (VTI).
- [4] Sandberg, Ulf and MASUYAME, Yukiei. Japanese machines for laying and cleaning double-layer porous asphalt – Observations from a study tour. Swedish National Road and Transport Research Institute (VTI) and Chalmers University of Technology, Sweden, 29-3-2001.
- [5] Voskuilen, Jan and van de Ven, Martin. Verslag bezoek Japan, 13-17 februari 2005. DWW.
- [6] MOTOMATSU, Shirou at. Al. How the Property and Performance of Polymer Modified Bitumen should be evaluated. In Porous Asphalt Mix? CD-rom proceedings from 3<sup>rd</sup> Eurasphalt & Eurobitumen Congress in Vienna 2004.

# 11. Contacts in Japan

## 11.1 Names and affiliation

1. Akihiro KONAGAI, Researcher, PWRI, Road technology research group, [konagai@pwri.go.jp](mailto:konagai@pwri.go.jp)
2. Takayuki AYABE, Researcher, PWRI, Road technology research group, [ayabe@pwri.go.jp](mailto:ayabe@pwri.go.jp)
3. Masahito FUJII, Researcher, PWRI, Road technology research group
4. Yukiei MASUYAMA, Chairman, Seikitokyu Kogyo Co. Ltd., member of PIARC group
5. Fuse SHINYA, Interpreter
6. Kazuyuki KUBO, Team leader, PWRI, Road technology research group
7. Yasufumi SAKAMOTO, Senior researcher, PWRI, Road technology research group
8. Junichi MINEGISHI, Researcher, Tokyo Metropolitan Government, Institute of civil engineering
9. Keizo KAMIYA, Director, Central Nippon Expressway Company Ltd., Road research department, [k.kamiya.ab@c-nexco.co.jp](mailto:k.kamiya.ab@c-nexco.co.jp)
10. Osamu FUNAHASHI, Central Nippon Expressway Company Ltd., Environmental and landscape division
11. Kunio NAKASAKI, Director, Central Nippon Expressway Company Ltd., Environmental and landscape division
12. Masaru TERADA, PWRI, Pavement research team
13. Koyu SUZUKI, Senior researcher, Road management technology center (ROMANTEC), pavement research division
14. Hiroshi MURAKAMI, Senior researcher, ROMANTEC, pavement research division
15. Hiromiki MURAKAMI, MLIT Kanto regional development bureau
16. Takeshi YUGE, MLIT Kanto regional development bureau
17. Masato MURAYAMA, Chief researcher (chairman), TOA DORO KOGYO Co. Ltd., Research laboratory, [murayama@toadoro.co.jp](mailto:murayama@toadoro.co.jp)
18. Mizuno GYOHTOKU, Manager (interpreter), TOA DORO KOGYO Co. Ltd., Information management section, [m\\_gyohtoku@toadoro.co.jp](mailto:m_gyohtoku@toadoro.co.jp)
19. Yoshio SAIKA, Director, TOA DORO KOGYO Co. Ltd., Research laboratory, [y\\_saika@toadoro.co.jp](mailto:y_saika@toadoro.co.jp)
20. Seishi MEIARASHI, Senior researcher, PWRI, Material and geotechnical engineering research group, [mei@pwri.go.jp](mailto:mei@pwri.go.jp)
21. Hiroshi KIDO, PWRI, Road technology research group
22. Osamu KAMADA, Researcher, PWRI, Road technology research group
23. Shohei SASAKI, Chief engineer, NIPPO Corporation, [sasaki\\_shouhei@nippo-c.jp](mailto:sasaki_shouhei@nippo-c.jp)
24. Masao WATANABE, General manager, NIPPO Corporation, [watanabe\\_masao@nippo-c.jp](mailto:watanabe_masao@nippo-c.jp)
25. Hidetoshi IZUMI, Manager, NIPPO Corporation, Technical development division, [izumi\\_hidetoshi@nippo-c.jp](mailto:izumi_hidetoshi@nippo-c.jp)

26. Yoshiteru KATO, Manager of research office, NIPPO Corporation,  
[katou\\_yoshiteru@nippo-c.jp](mailto:katou_yoshiteru@nippo-c.jp)
27. Jun TAKO, Director of maintenance and management division, Civil engineering research institute of Hokkaido (CERI), road department, [takou@ceri.go.jp](mailto:takou@ceri.go.jp)
28. Kazunori SOUMA, Director, CERI, [souma-k@ceri.go.jp](mailto:souma-k@ceri.go.jp)
29. Manabu CHIBA, Researcher, CERI, [chiba\\_m@ceri.go.jp](mailto:chiba_m@ceri.go.jp)
30. Ryuji ABE, Senior research engineer, CERI, [aber@ceri.go.jp](mailto:aber@ceri.go.jp)
31. Tateki ISHIDA, Deputy director of maintenance and management division, CERI,  
[t-ishida@ceri.go.jp](mailto:t-ishida@ceri.go.jp)
32. Tetsuji OTA, Director, East Nippon expressway co. ltd., [t.ota.ad@e-nexco.co.jp](mailto:t.ota.ad@e-nexco.co.jp)
33. Kunio TOYOTA, Chief engineer, East Nippon expressway co. ltd.,  
[k.toyota.aa@e-nexco.co.jp](mailto:k.toyota.aa@e-nexco.co.jp)
34. Masaru MIYAKE, Engineer, East Nippon expressway co. ltd.
35. Tomoyuki FUJINO, Leader project management team, East Nippon expressway co. ltd., [t.fujino.aa@e-nexco.co.jp](mailto:t.fujino.aa@e-nexco.co.jp)
36. Shigeo IWAI, Professor, Nihon university, College of science & technology,  
[siwai@trpt.cst.nihon-u.ac.jp](mailto:siwai@trpt.cst.nihon-u.ac.jp)
37. Masaru SHIMAZAKI, Senior researcher, Taisei Rotec Corporation,  
[masaru\\_shimazaki@taiseirotec.co.jp](mailto:masaru_shimazaki@taiseirotec.co.jp)

## 11.2 Contact addresses

PWRI, Public Works Research Institute, 1-6 minamihara, Tsukuba-shi, Ibaraki-ken, Japan.

Seikitokyu Kogyo Company Ltd., General contractor, Laboratory: 2081-2, Shizuwa, Iwafune-cho, Shimotsuga-gun, Tochigi-ken, 329-4304, Japan.

Central Nippon Expressway Company Ltd., 1-4-1, Tadao, Machida-city, Tokyo, 194-8508, Japan.

East Nippon Expressway Company Ltd., 5-12-15, Oyachi-nishi, Atsubetsu-ku, Sapporo, 004-0042 Japan.

Road management technology center (ROMANTEC).

Tokyo Metropolitan Government, Institute of civil engineering.

MLIT Kanto regional development bureau.

TOA DORO KOGYO Company Ltd., 3-7, Roppongi 7-chome, Minato-ku, Tokyo 106-0032, Japan.

NIPPO CORPORATION, 6-70, Mihashi, Nishi-ku, Saitama, 331-0052 Japan.

CERI, Civil Engineering research institute of Hokkaido, Hiragishi 1-3-1-34, Toyohira-ku, Sapporo, 062-8602 Japan.

Nihon University, College of science & technology, Department of transportation engineering & socio-technology, 7-24-1 Narashinodai, Funabashi, Chiba 274-8501, Japan.

Taisei Rotec Corporation, 1456, Kamiya Kounosu-shi, Saitama 365-0027 Japan.

### **11.3 The Dutch-Danish delegation**

Ministry of Transport Public Works and Water Management

Road and Hydraulic Engineering Division (DWW)

P.O. Box 5044

NL-2600 Ga Delft

The Netherlands

Tel: +31 15 251 8518

Fax: +31 152518555

[www.rws.nl/rws/dww/home/engels/index\\_eng.html](http://www.rws.nl/rws/dww/home/engels/index_eng.html)

Danish Road Directorate / Danish Road Institute (DRI)

Guldalderen 12

DK-2640 Hedehusene

Denmark

Tel.: +45 4630 7000,

Fax: +45 4630 7105

[www.roadinstitute.dk](http://www.roadinstitute.dk)

**Dr. Rob Hofman** is currently within the Noise Innovation Program (IPG) program manager Silent Pavements. Since 1999 he is working for the DG Public Works and Water Management of the Dutch Ministry of Transport. He has been involved in; the development of new laboratory techniques and implementation of innovative solutions for road construction and maintenance. This includes innovations like Energy Conversion in/along the Road, Dynamic Marking Materials and Silent Pavements. Currently he coordinates the research on Silent Pavements that will be implemented on the Dutch Main Network before the end of this decade. He is also chairman of the Dutch Workgroup for implementation of new European Test Methods. He got his MSc and PhD degree in the field of Chemical Technology in the specialization of Materials Technology. The topic of the PhD-thesis is durability of construction materials for Energy Plants. He has been involved in research in durability studies of several materials within the Joint European Research Centre (Ispra, Italy) and the Technical University of Delft (Netherlands).

**M. Sc. Hans Ertman Larsen** Deputy Director of the Danish Road Institute and Head of the Asphalt Department. He has been employed at the Danish Road Directorate, Danish Road Institute in Denmark since 1971. He graduated with a M.Sc. in Structural Engineering From Denmark's Technical University in 1969. He has gained experience in R&D through his many years of leadership duties at the Institute and through his work as loaned staff at the SHRP projects in USA and also through his involvement in international bodies such as PIARC, OECD, TRB, FEHRL and the Nordic Road

Association. As an example, he has been a member of several OECD Scientific Expert Groups, Member of PIARC Technical Committee on Flexible Roads, a member of the SHRP LTPP Advisory Committee and member of FHWA, SHRP-LTPP Implementation Working Group.

**M. Sc. Bent Andersen** is a Senior Researcher at the Danish Road Institute/Road Directorate. He holds a Master of Science in Electrical Engineering from the Technical University of Denmark. His field of specialization is acoustics. Following 6 years of work within hearing-aid research (electro-acoustic measurements and subjective listening tests) he has been working with measurement and prediction of external noise from traffic (roads, railways, and air traffic), industrial plants, and machinery (including wind turbines) – at first with Delta Acoustics and Vibration, later on with dk-TEKNIK Energy and Environment. He is a specialist within outdoor sound propagation and noise from wind turbines. He has great experience in measurement of vibrations and of occupational noise, infra sound, low frequency noise, and consultancy on noise control (including noise damping of machinery and plants, noise shielding, or sound insulation). He is also experienced as a project leader of interdisciplinary research and development projects, and has participated in various standardisation working groups. Furthermore he has experience with quality assurance within the acoustical field (including calibration) and with consultancy on environmental administration of noise issues (environmental approval, environmental management). He is working with international research and development of noise reducing pavements in the DRI-DWW noise abatement program, the joint EU projects SILVIA and SILENCE. Since 1994 he is an expert member of the Danish Environmental Appeal Board.

**M.Sc. Hans Bendtsen** is a Senior Researcher at the Danish Road Institute/Road Directorate with over 20 years of experience. He graduated as an Engineer with a M.Sc. in town and traffic planning from Denmark's Technical University in 1979. He is a specialist in road traffic noise with a focus on noise reducing pavements. He have been the project leader for many of the Danish research and development projects on noise reducing pavements with expertise in single and twin-layer porous pavements as well as thin layers. He is working with international research and development in the DRI-DWW noise abatement program, the joint EU projects SILVIA and SILENCE. He is author of many articles and papers given at international conferences and journals. Known for a comprehensive approach to research projects combining acoustics, road technology, traffic safety, cost benefit, social studies, traffic engineering etc. Have for periods he have been working at the Danish Transport Research Institute and Atkins Consultants. He is an expert member of the Danish Environmental Appeal Board. He has been member of OECD expert groups, Nordic Road Association and several technical comities and advisory boards.

**Dr. Carsten Bredahl Nielsen** Senior Researcher at the Danish Road Institute/Road Directorate since 1992. He graduated as an Engineer with a M.Sc. in civil engineering from the Technical University of Denmark in 1988. In 1991 he finished a Ph.D. study on durability of porous building materials at the Technical University. Dr. Nielsen has gained wide experience as a specialist in durability and deterioration of porous building materials during the preparation of his Ph.D thesis and later in asphalt pavement

maintenance and materials technology, functional properties of asphalt pavements and rut testing during his work at the Danish Road Institute. He has been responsible for development of a new loading machine to test rutting resistance of asphalt pavements. He is a specialist in image analyses of thin and plane sections of pavement samples and is also working with CT scanning for 3 dimensional pavement analyses. He has been leader of projects on improving the structural lifetime of porous pavements. He has been expert adviser on a road rehabilitation project in Zambia. In 2004 he organized an international road conference in Copenhagen.



## 12. Program for the scanning tour

### Sunday 13th November

---

- 08:45 Arrival at Narita and meet with Mr. KUBO (PWRI)  
Transfer from Narita to Tsukuba (by express bus) with Mr. KUBO (PWRI)  
Stay at Tsukuba Hotel Grand Shinonome
- 

### Monday 14th November

---

- 09:00 Meet with Mr. KONAGAI (PWRI), move to PWRI by PWRI's car  
09:30 Introduction of PWRI.  
Mr. KUBO (PWRI)  
09:50 Introduction to the IPG road noise road research program in the Netherlands.  
Dr. Rob Hofman (DWW)  
The DRI-DWW noise abatement program.  
M. Sc. Hans Ertman Larsen (DRI)  
10:40 Practical use of noise reducing pavements in warm area.  
Mr. SAKAMOTO (PWRI).  
Mr. MINEGISHI (Tokyo Metropolitan Government)  
Overview of Studies on Materials and Mix in Long Service  
Mr. KAMIYA (Central NEXCO)  
Trend of Air Void Assessment Technology  
Mr. FUNAHASHI (Central NEXCO)  
Practical use of porous pavements in the Netherlands.  
Dr. Rob Hofman (DWW)
- 
- 12:10 Lunch
- 
- 13:10 Pavement management systems in Denmark  
M. Sc. Hans Ertman Larsen (DRI)  
14:00 Method for evaluating tire/road noise level  
Mr. TERADA (PWRI)  
Mr MURAKAMI (ROMANTEC)  
14:40 Development and the future of function recovery  
Maintenance machine of porous pavement in Japan  
Mr. YUGE & Mr. MURAKAMI (MLIT Kanto Regional Development Bureau)  
Mr SUZUKI (ROMANTEC)  
Mr. MASUYAMA (Seikitokyukogyo)  
Knowledge on clogging of porous pavements in Denmark  
Dr. Carsten Bredahl Nielsen (DRI)  
15:40 Demonstration. Cleaning procedures for porous pavements in Japan  
Mr. YUGE & Mr. MURAKAMI (MLIT Kanto Regional Development Bureau)  
Mr. MASUYAMA (Seikitokyukogyo)  
16:30 Transfer to Hotel by PWRI's car with Mr. AYABE (PWRI)  
17:00 Stay at Tsukuba
-

## **Tuesday 15<sup>th</sup> November**

---

- 09:00 Meet with Mr. AYABE (PWRI) at hotel and transfer to PWRI by PWRI's car
- 09:30 Elastic porous pavements  
Dr. MEIARASHI (PWRI)
- 10:15 Laboratory tour in PWRI. Test field of Elastic porous pavements  
Mr. KIDO (PWRI)
- 11:00 Structural durability of porous pavements in Japan  
Dr. KAMADA (PWRI)  
Improving the structural lifetime of porous pavements in Denmark  
Dr. Carsten Bredahl Nielsen (DRI)
- 
- 12:10 Lunch
- 
- 13:10 Test of two layer porous pavements in Denmark  
M. Sc. Hans Bendtsen (DRI)  
Test of noise reducing thin layers in Denmark  
M. Sc. Bent Andersen (DRI)
- 14:00 Transfer to Road Company TOA DORO KOGYOI by PWRI's car  
Mr. KONAGAI & Mr. AYABE (PWRI)
- 14:15 Arrival at TOA Doro Kogyo
- 14:20 Improving the structural durability of porous pavements  
Dr. MURAYAMA (TOA DORO KOGYO Research Laboratory)  
Laboratory tour; Laboratory for New Material test
- 16:00 Transfer to Hotel by PWRI's car
- 16:30 Stay at Tsukuba
- 

## **Wednesday 16<sup>th</sup> November**

---

- 08:00 Meet with Mr. KONAGAI & Mr. AYABE (PWRI) at hotel
- 08:10 Transfer to ROAD Company NIPPO Corporation by train
- 10:00 Two-layer porous asphalt pavement in Japan  
Noise reducing thin layers pavements or other new pavements in Japan  
Mr. WATANABE (NIPPO Corporation)
- 
- 12:00 Lunch
- 
- 13:00 Transfer to Yokohama by train by Mr. WATANABE (NIPPO Corporation)
- 13:45 Site Inspection, Noise reducing new pavement in service on Route 1 in Yokohama  
Mr. WATANABE (NIPPO Corporation)
- 14:45 Transfer to Haneda airport by express bus with Mr. KONAGAI & Mr. AYABE (PWRI)
- 17:00 Transfer to Shin-Chitose airport by airline
- 18:30 Meet with Mr. TAKO (CERI)  
Transfer to Sapporo by train with Mr. TAKO (CERI)
- 20:00 Stay at Sapporo
-

### **Thursday 17<sup>th</sup> November**

---

- 09:00 Meet with Mr. ISHIDA (CERI) at hotel  
Transfer to CERI by CERI's bus
- 09:30 Practical use of noise reducing pavements in cold area.  
Winter maintenance of porous pavements in Japan.  
Mr. ISHIDA, etc. (CERI)  
Winter maintenance of porous pavements in the Netherlands  
Dr. Rob Hofman (DWW)  
Laboratory tour in CERI with Mr. ISHIDA, etc. (CERI)
- 
- 12:00 Lunch
- 
- 13:00 Visiting practical roads (including highway) in service by CERI's car with Mr. ISHIDA
- 17:00 Transfer to Hotel by CERI's car with Mr. ISHIDA  
Stay at Sapporo
- 

### **Friday 18<sup>th</sup> November**

---

- 8:30 Transfer to Shin-Chitose airport by train
- 10:30 Transfer to Haneda airport by airline
- 12:05 Transfer to Tokyo by train  
Free time  
Transfer to Narita (Narita st. or Keisei Narita st.) by train  
Move to Hotel by shuttle bus  
Stay at Narita
- 

### **Saturday 19<sup>th</sup> November**

---

- Transfer to Narita airport by shuttle bus  
Departure from Narita
-



Eksternt notat / Technical notes		
Nr. No.	Titel/Title/Shortcut	Forfatter/Author
11/00	Temperaturer i vejbefæstelser	Susanne Baltzer Brian Henriksen Ole Fog
12/01	Vejens egenskaber - fra måleure og regnestok til sensorer og pc'ere (Ikke i elektronisk udgave)	Jørgen Banke
13/02	The Danish Road Testing Machine 1995 - 2000	Wei Zhang Robin Macdonald
14/02	Sammenligning mellem Viagraf og viagrafækvivalent beregnet ud fra profilografmålinger	Bjarne Schmidt
15/02	Rensning af overfladevand og husholdningsspildevand	Gitte Falstrup Knud A. Pihl
16/03	Statisk pladebelastning, faldlod og minifaldlod Resultater af sammenlignende målinger	Gregers Hildebrand Susanne Baltzer
17/03	Stenfyldte fuger	Vibeke Wegan
18/03	Vejens jævnhed og bilers hastighed - er oplevelsen af en vejs jævnhed afhængig af bilens hastighed?	Bjarne Schmidt
19/04	Støjdæmpende vejbelægninger på Motorring 3 Teknisk og samfundsøkonomisk analyse	Carsten Bredahl Nielsen
20/04	Vejstøj på Inter-Noise konferencen i Prag - rejserapport august 2004	Hans Bendtsen Bent Andersen
21/04	Måling af trafikstøj fra vejbelægninger på M10 ved Solrød	Bent Andersen, Hans Bendtsen, Bjarne Schmidt Carsten Bredahl Nielsen
22/04	Sammenhæng mellem vejbelægningers tekstur og trafikstøj - et litteraturstudium	Bent Andersen
23/04	Rolling resistance, fuel consumption - a literature review	Hans Bendtsen
24/05	The DRI – DWW Noise Abatement Program - Project description	Hans Bendtsen H.J. Ertman Larsen Bent Andersen Carsten Bredahl Nielsen Jørn Raaberg Vibeke Wegan Bjarne Schmidt Karin Kool Ammitsøe
25/05	Holdbarhed af Drænasfalt – asfaltprøvning	Carsten Bredahl Nielsen
26/05	Thin layer Test Pavements in Denmark -Project description	Hans Bendtsen
27/05	Notes from Forum Acusticum in Budapest 2005	Hans Bendtsen Bent Andersen Lars Ellebjerg Larsen
28/05	French Experiences on Noise Reducing Thin Layers	Hans Bendtsen Jørn Raaberg
29/05	International Experiences with Thin Layer Pavements	Hans Bendtsen Jørn Raaberg Sigurd N. Thomsen
30/05	Traffic noise at two-layer asphalt – Øster Søgade Year no. 6	Jørgen Kragh
31/05	Noise reducing pavements in Japan - study tour report	Carsten Bredahl Nielsen Hans Bendtsen Bent Andersen H.J. Ertman Larsen



Road Directorate  
Niels Juels Gade 13  
P.O. Box 9018  
DK-1022 Copenhagen K  
Denmark  
Telephone +45 3341 3333  
Telefax +45 3315 6335

Road Directorate  
Guldalderen 12  
P.O. Box 235  
DK-2640 Hedehusene  
Denmark  
Telephone +45 4630 7000  
Telefax +45 4630 7105

Road Directorate  
Thomas Helsteds Vej 11  
P.O. Box 529  
DK-8660 Skanderborg  
Denmark  
Telephone +45 8993 2200 [vd@vd.dk](mailto:vd@vd.dk)  
Telefax +45 8652 2013 [Vejdirektoratet.dk](http://Vejdirektoratet.dk)